

FINISHES

Variety is the spice of life

LOFTWALL



FRAMEWALL

Page 2

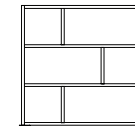

PIVOT

Page 3

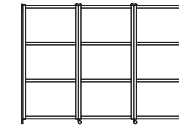

GLIDE

Page 4

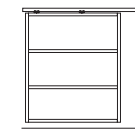

SHIFT

Page 5

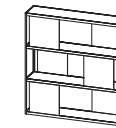

TEMPO

Page 6

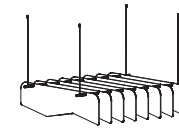

HITCH

Page 7

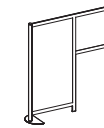

SPLIT

Page 8

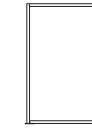

DESK SHIELD

Page 8

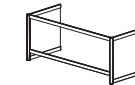

COUNTER SHIELD

Page 9



SHELTER

Page 10

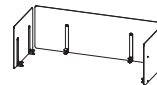

HIDE

Page 10

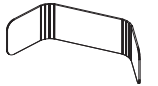

PARALLEL

Page 11

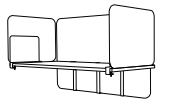

FLOX

Page 11

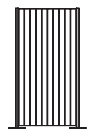

DOK

Page 12



HOVER

Page 13

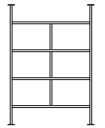

WEAVE

Page 14

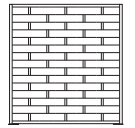

CHISEL

Page 14

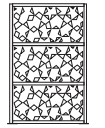

WEB

Page 15

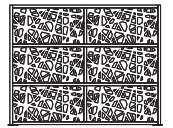

WAVE

Page 15



BLOX

Page 16

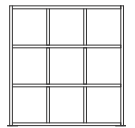

FRAMEWALL

For when you need to divide and conquer

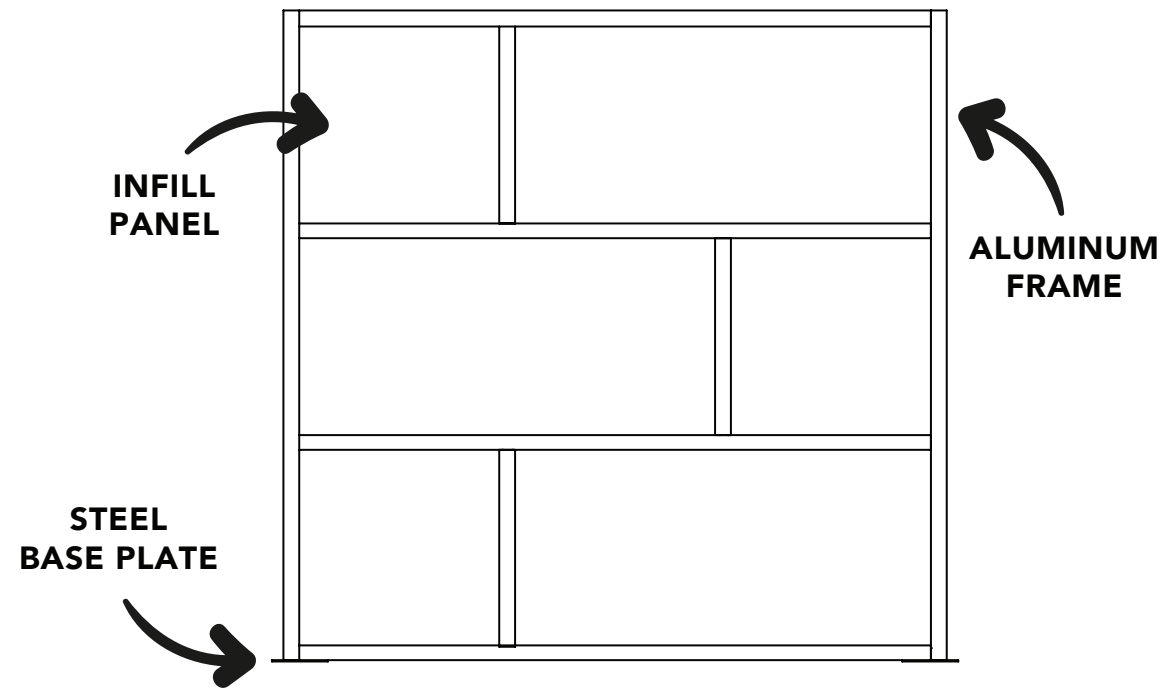

FRAME FINISHES

*Frames are made of anodized aluminum

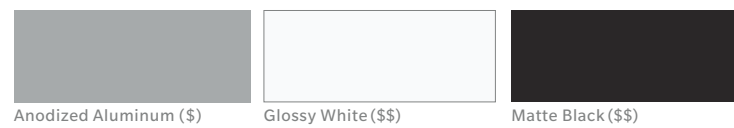

BASE PLATE FINISHES

*Base plates are made of steel



PANEL FINISHES

Laminate (\$\$)

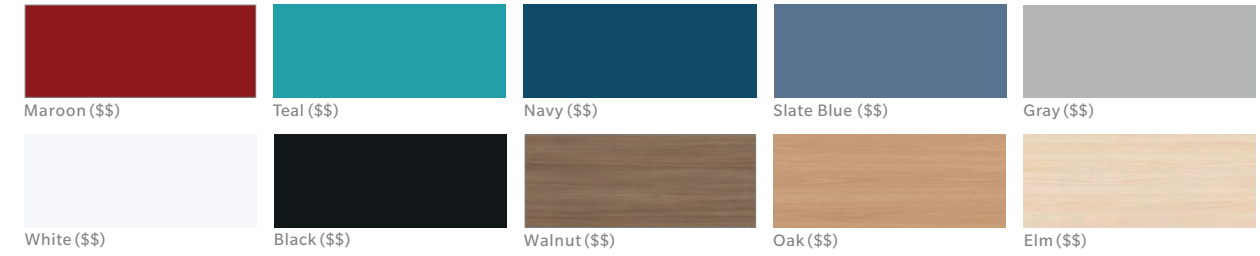

Blox (\$\$\$)

*Blox is made of premium, recycled wool blends **Only available as 2' x 4' panels

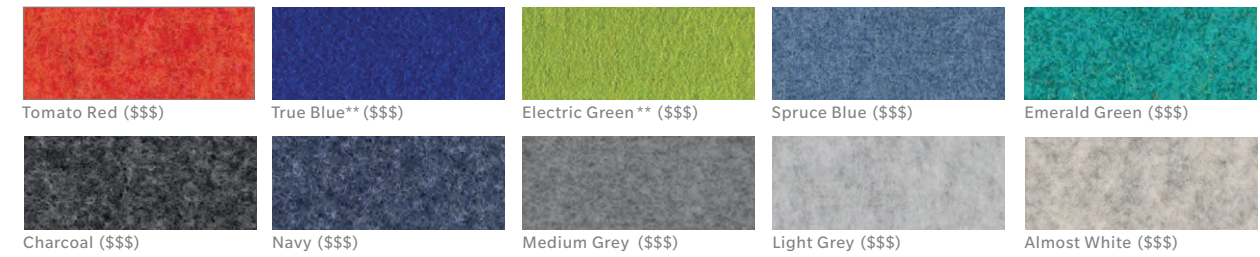

Felt (\$\$)



Akustik (\$)

*Akustik is made of recycled PET material

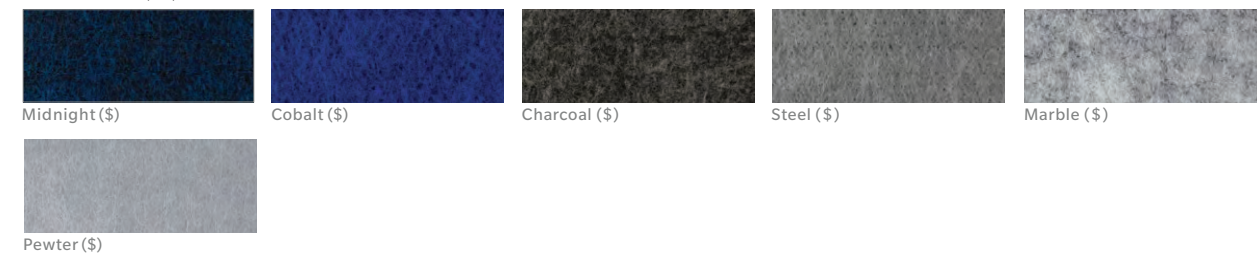

Writable (\$\$)



Translucent (\$ - \$\$)



Specialty Panel Finishes

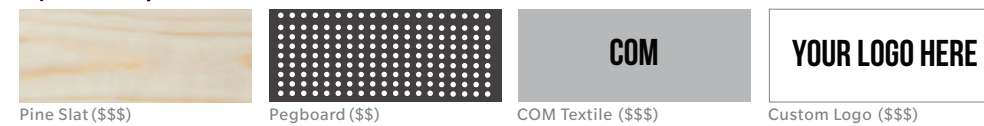

PIVOT

A lot of privacy for a little footprint

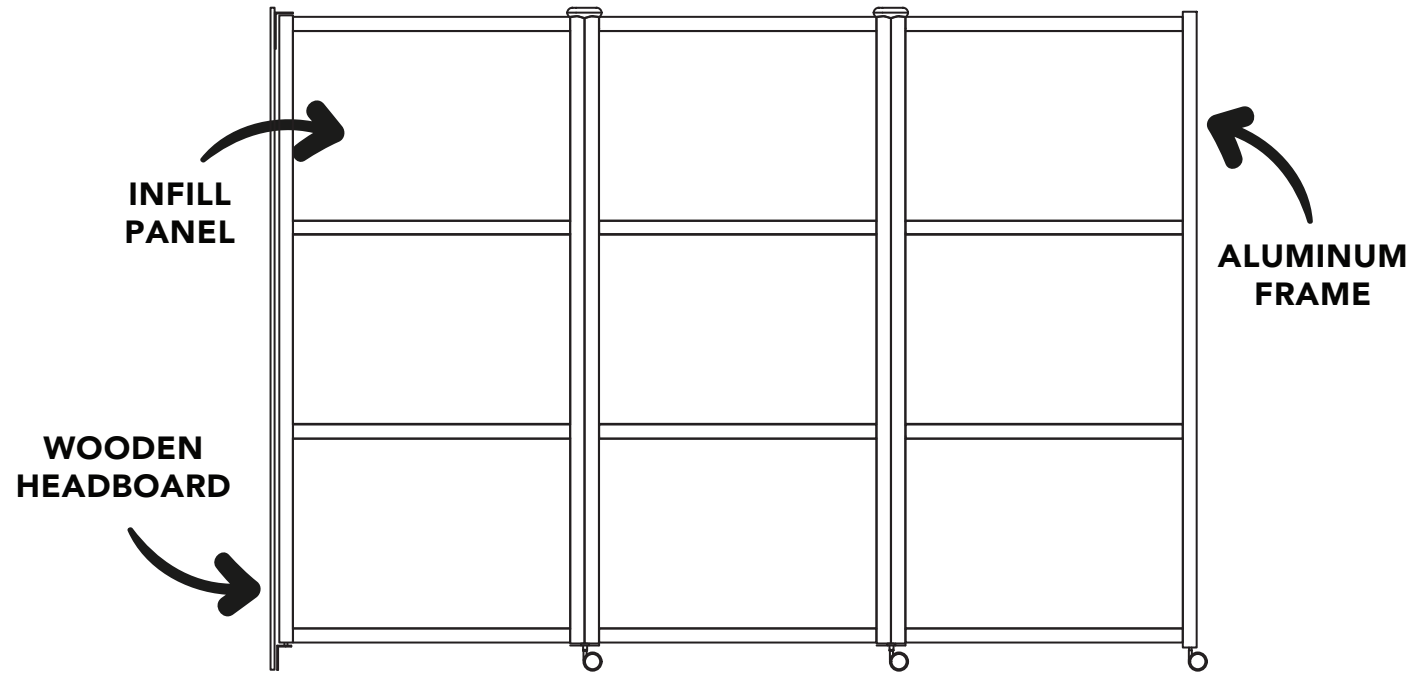

PANEL FINISHES

Laminate (\$\$)

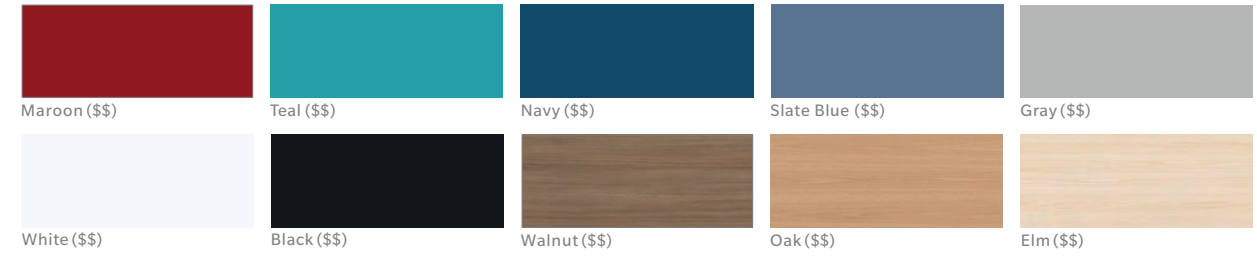

Felt (\$\$)



Akustik (\$)

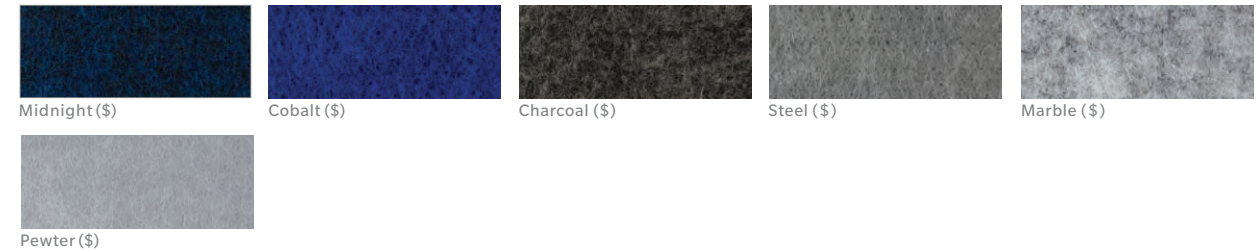

Writable (\$\$)



Translucent (\$ - \$\$)

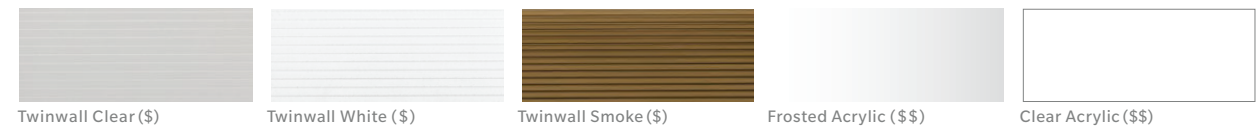

Specialty Panel Finishes



FRAME FINISHES

*Frames are made of anodized aluminum



HEADBOARD FINISHES



GLIDE

Sliding privacy, concealed magic

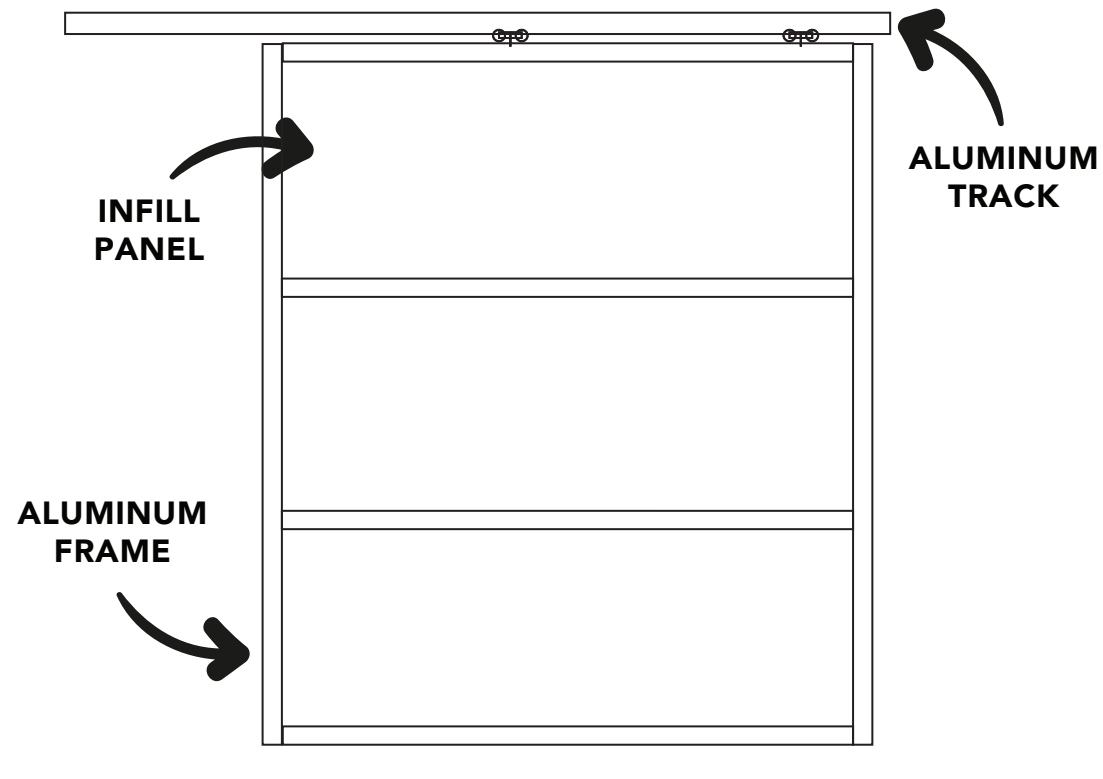

PANEL FINISHES

Laminate (\$\$)

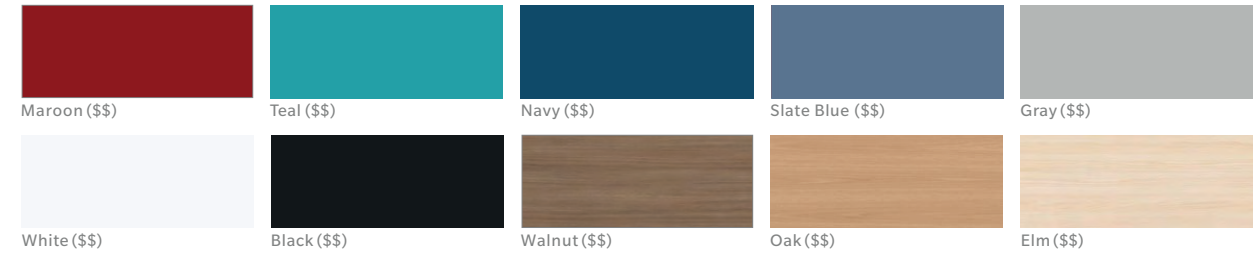

Felt (\$\$)



Akustik (\$)

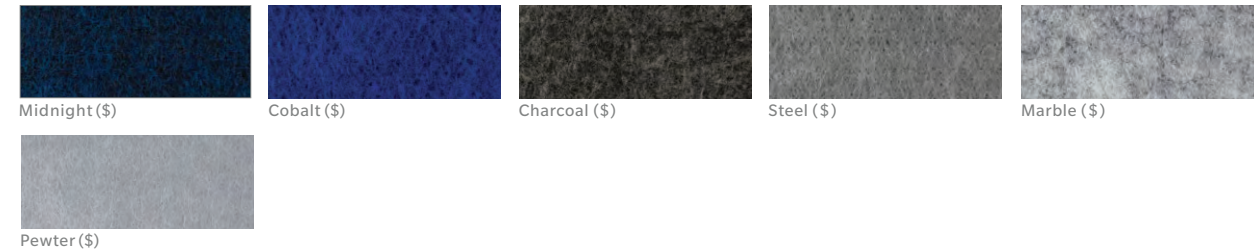

Writable (\$\$)



Translucent (\$ - \$\$)

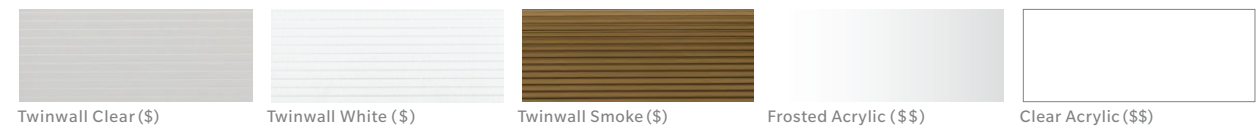

Specialty Panel Finishes



FRAME FINISHES



TRACK FINISHES

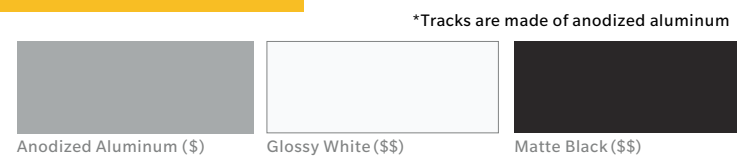

SHIFT

When full coverage privacy is needed

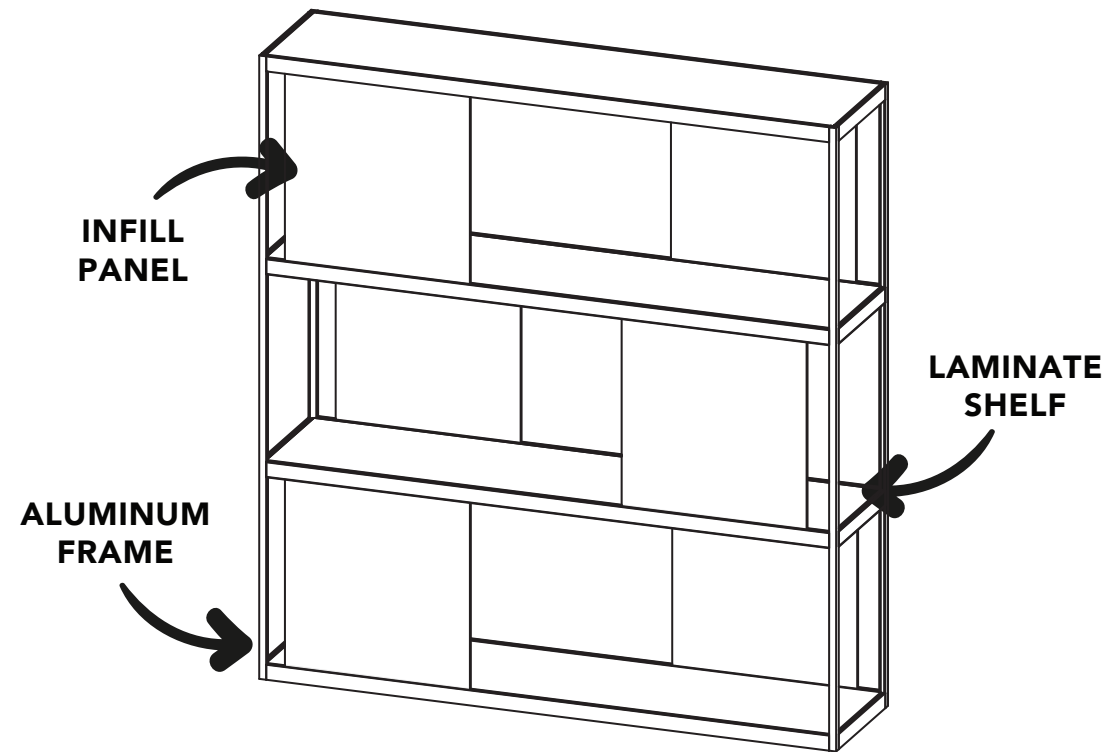

FRAME FINISHES

*Frames are made of anodized aluminum

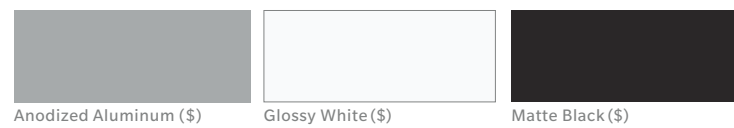

SHELF FINISHES



PANEL FINISHES

Laminate (\$\$)

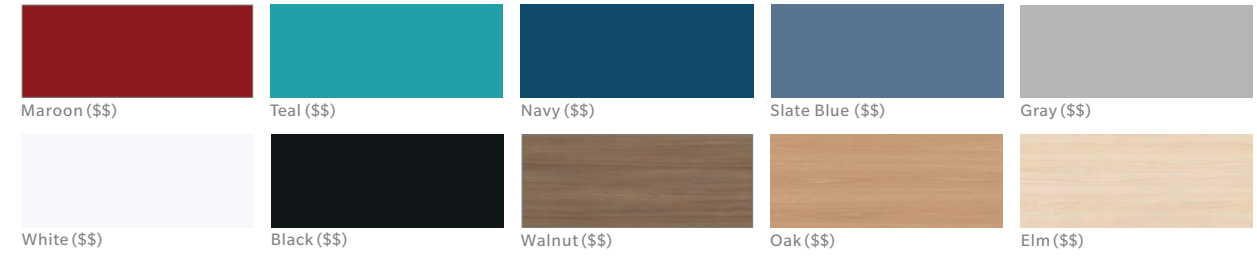

Blox (\$\$\$)

*Blox is made of premium, recycled wool blends

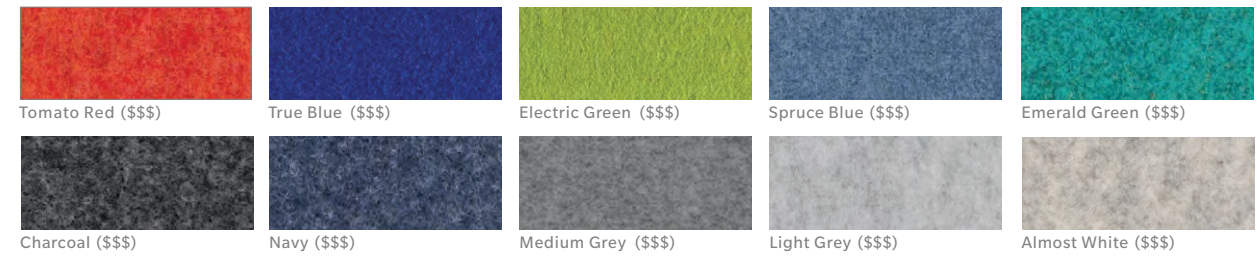

Felt (\$\$)



Akustik (\$)

*Akustik is made of recycled PET material

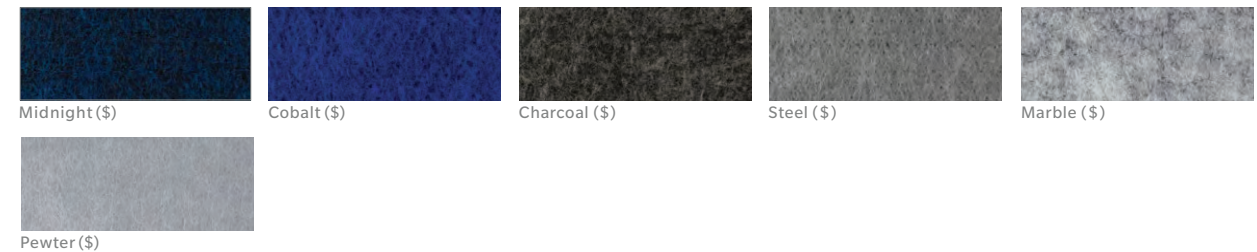

Writable (\$\$)



Translucent (\$ - \$\$)



Specialty Panel Finishes



TEMPO WALL

Turn down the volume, with style

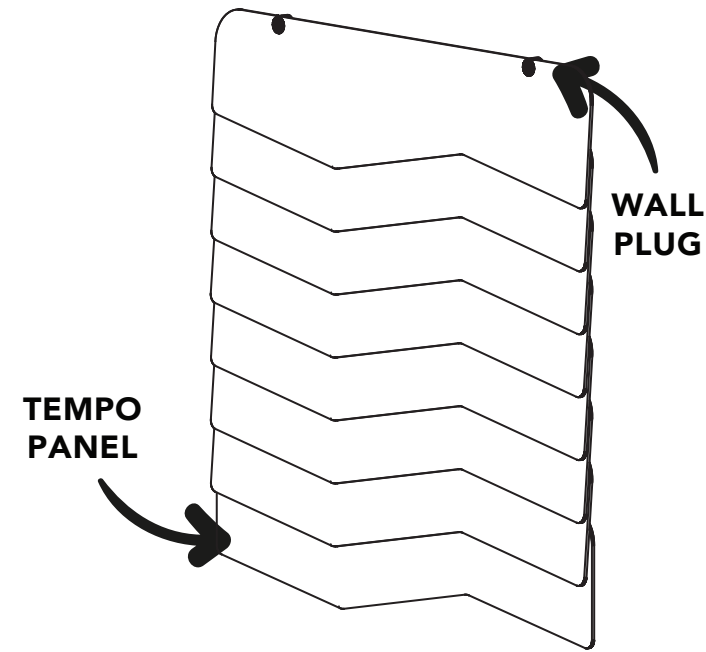

WALL PLUG FINISH



Cork (\$)

PANEL FINISHES

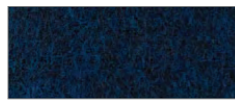

Midnight (\$)



Cobalt (\$)



Charcoal (\$)

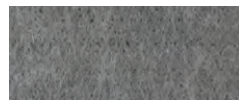

Steel (\$)



Marble (\$)

*Tempo panels are made from recycled PET material

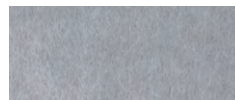

Pewter (\$)

TEMPO CEILING

Turn down the volume, with style

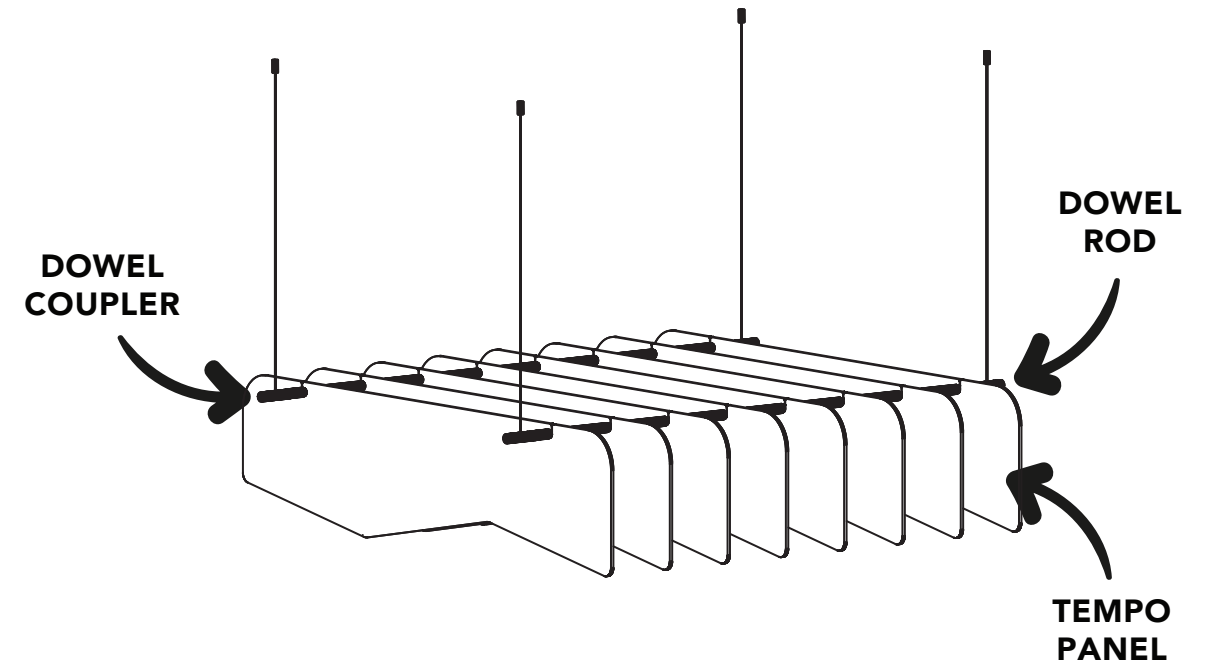

DOWEL ROD FINISHES



White Ash (\$)



Aspen (\$\$)



Ebony (\$\$)

DOWEL COUPLER FINISHES



Silver (\$)

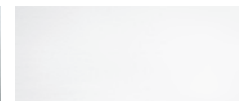

White (\$\$)

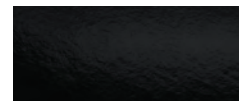

Black (\$\$)

PANEL FINISHES



Midnight (\$)



Cobalt (\$)



Charcoal (\$)

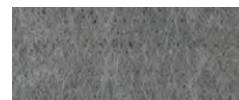

Steel (\$)



Marble (\$)



Pewter (\$)

*Tempo panels are made from recycled PET material

HITCH

Tie privacy to any workstation

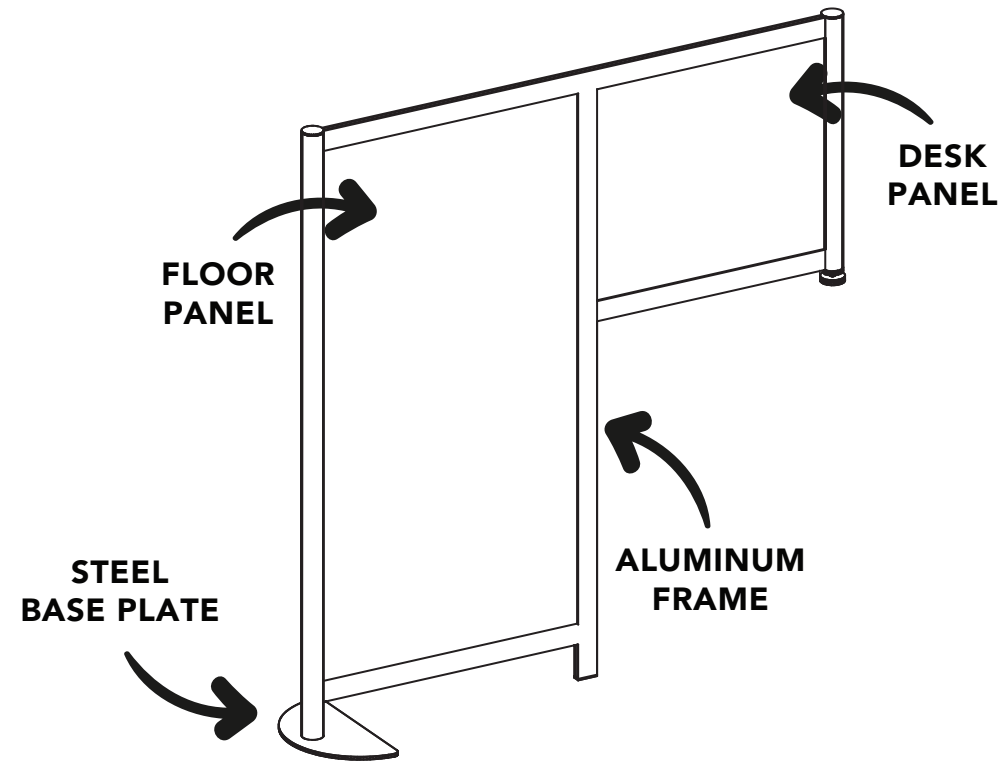

FRAME FINISHES

*Frames are made of anodized aluminum



BASE PLATE FINISHES

*Base plates are made of steel



PANEL FINISHES

Laminate (\$)

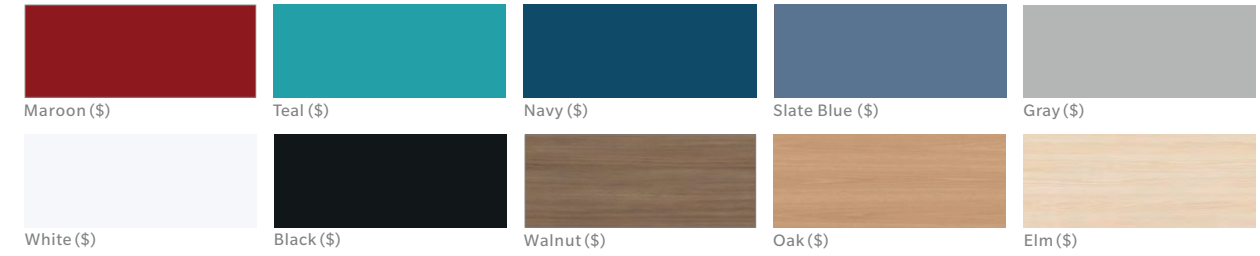

Blox (Floor panel only) (\$)

*Blox is made of premium, recycled wool blends

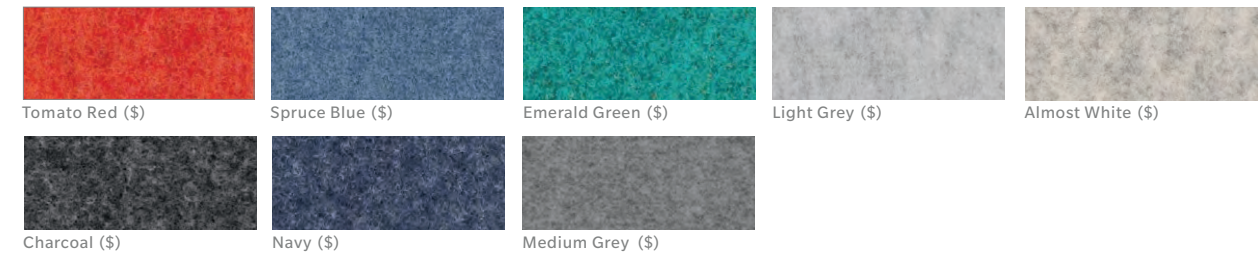

Felt (\$)

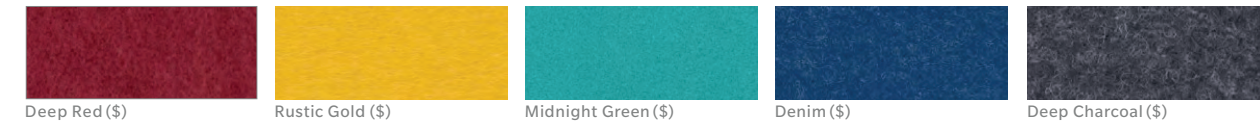

Akustik (\$)

*Akustik is made of recycled PET material

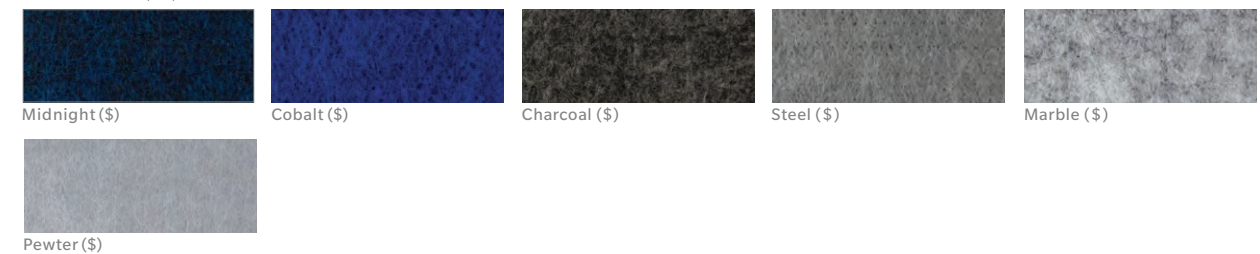

Writable (\$)



Translucent (\$)



Specialty Panel Finishes



SPLIT

Divide without sacrificing natural light

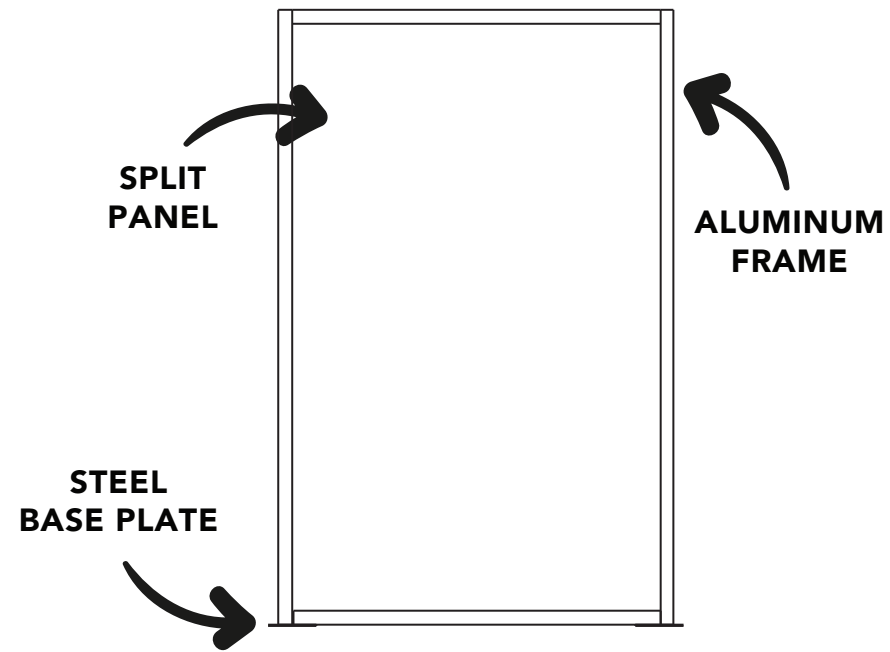

FRAME FINISHES

*Frames are made of anodized aluminum



BASE PLATE FINISHES

*Base plates are made of steel



PANEL FINISHES



DESK SHIELD

A refuge from distractions and germs

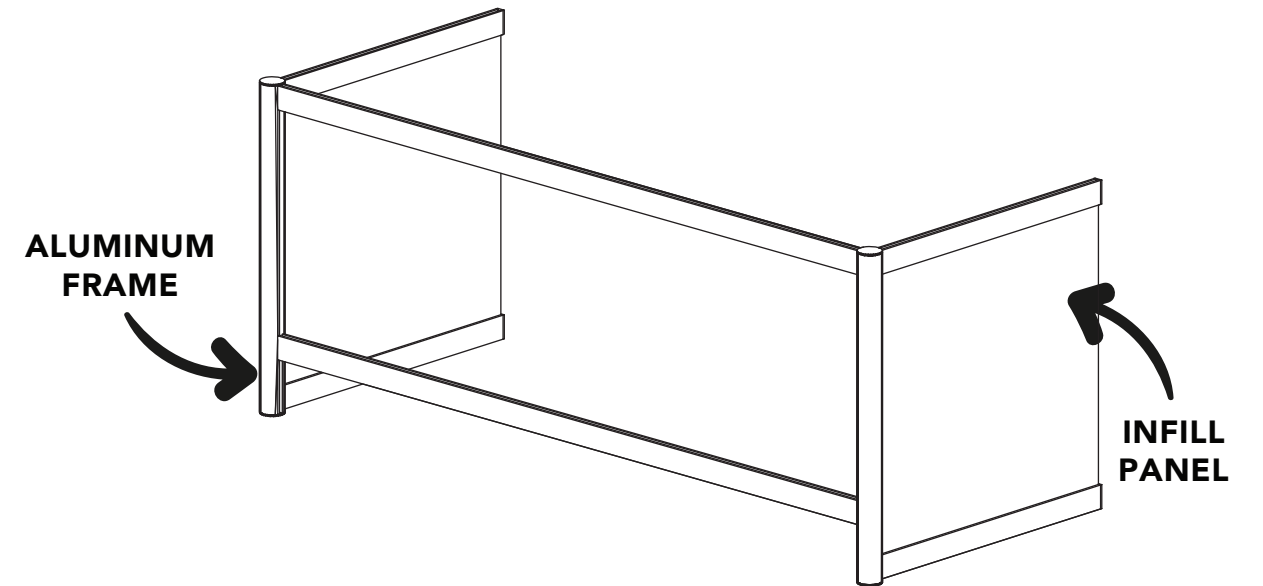

FRAME FINISHES

*Frames are made of anodized aluminum



PANEL FINISHES



COUNTER SHIELD

A family of healthcare-grade sneeze guards

FRAME FINISHES



Anodized Aluminum (\$)

PANEL FINISHES



Clear Acrylic (\$\$)

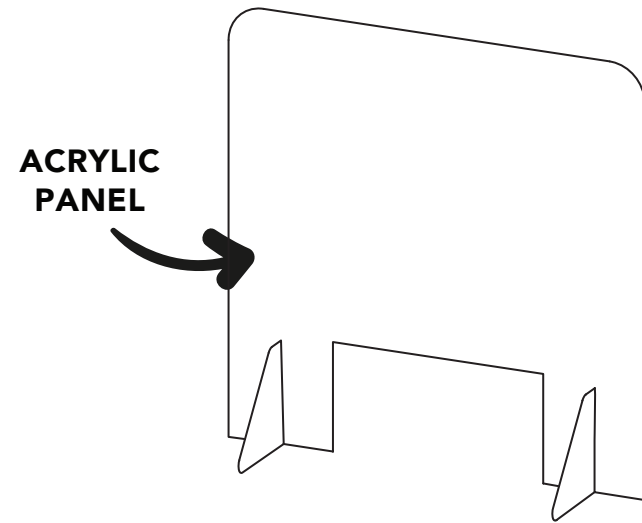

ACRYLIC
PANEL

LITE STYLE

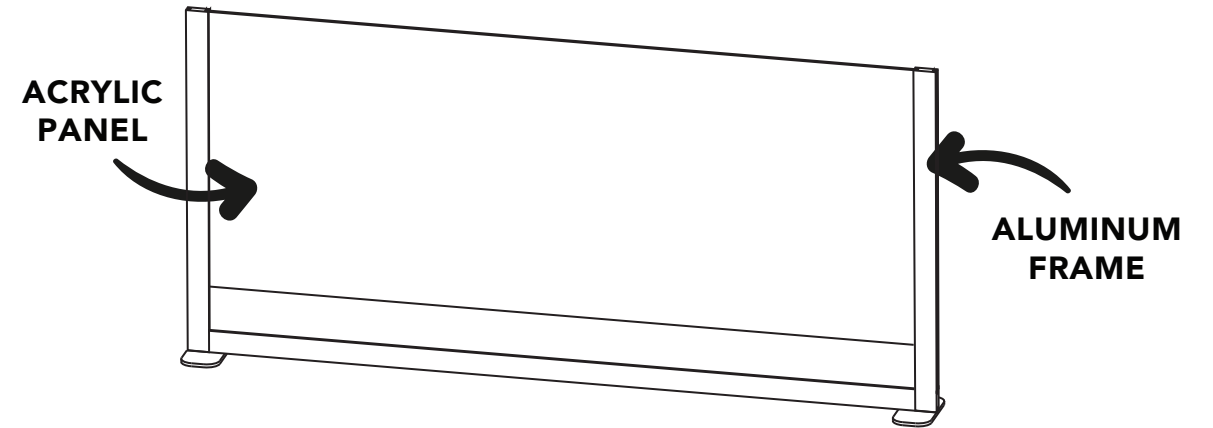

ACRYLIC
PANEL

ALUMINUM
FRAME

BASIC STYLE

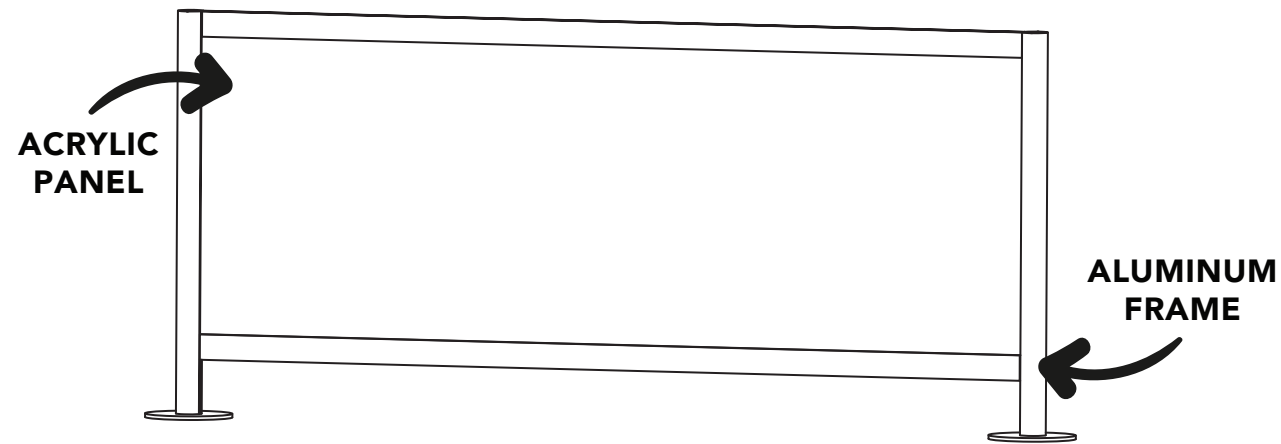

ACRYLIC
PANEL

ALUMINUM
FRAME

CLASSIC STYLE

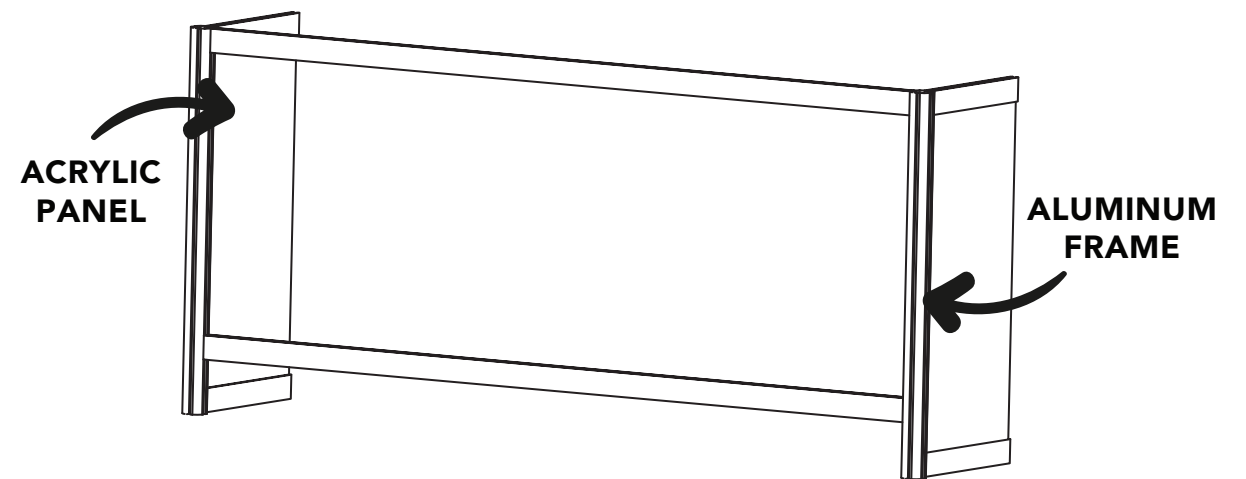

ACRYLIC
PANEL

ALUMINUM
FRAME

WRAP STYLE

SHELTER

A safe place to touch down and work

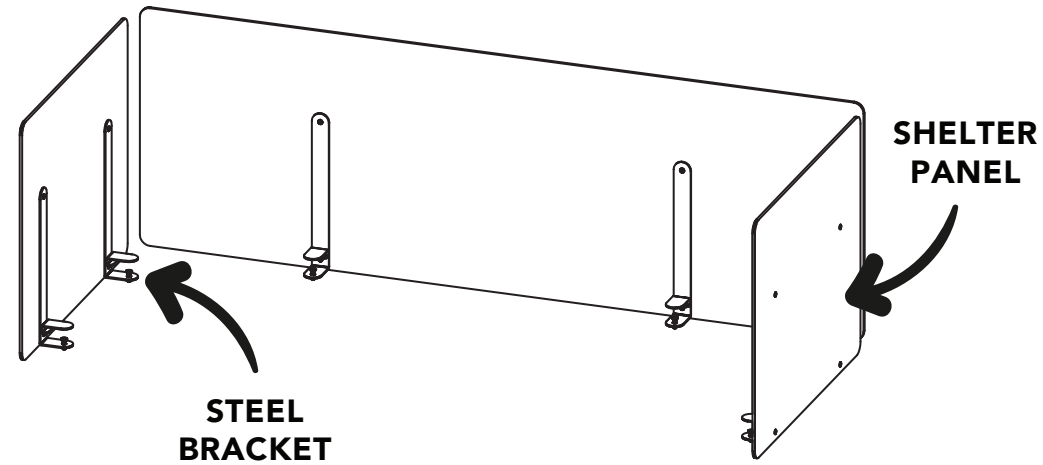

BRACKET FINISH



PANEL FINISHES

Akustik (\$)

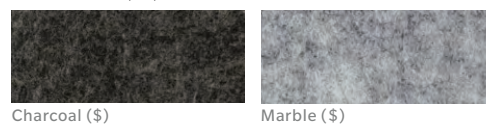

Transparent (\$\$)

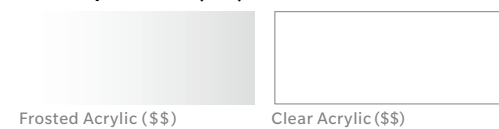

HIDE

A hassle-free escape from the chaos

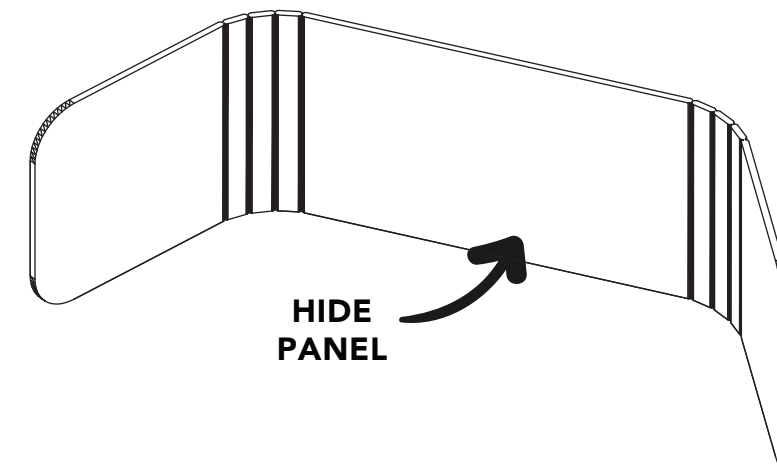

PANEL FINISHES



PARALLEL

The most flexible way to divide your desk

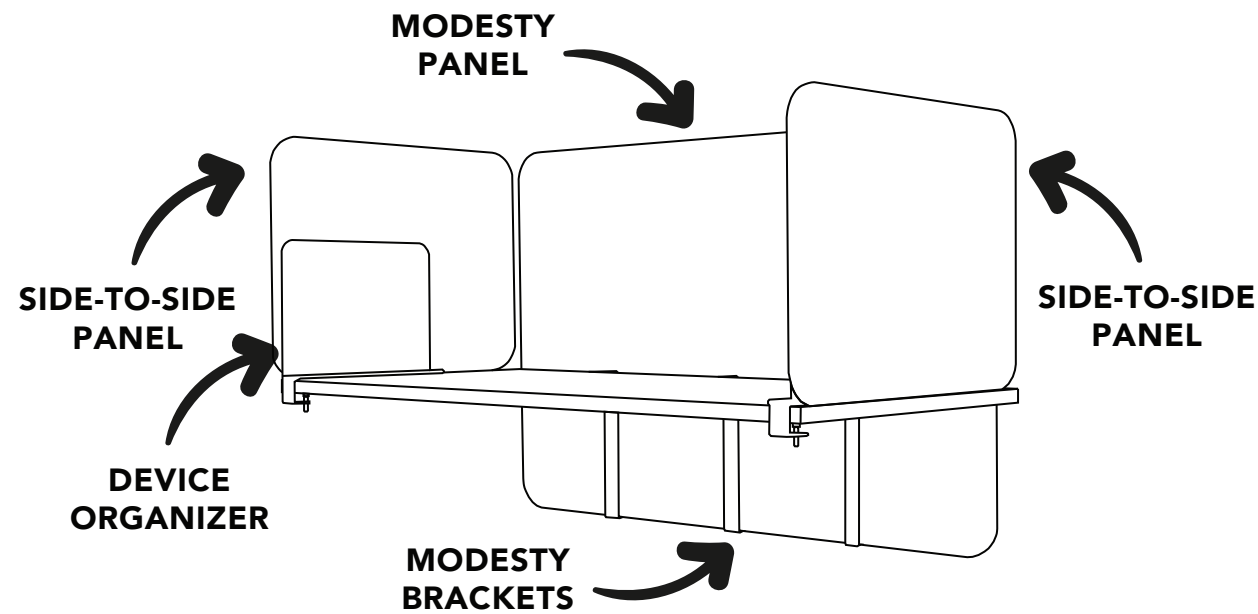

BRACKET FINISH

Device Organizer and Modesty Bracket



Magnetic Dry Erase (\$)

PANEL CORE FINISHES



Charcoal (\$)



Marble (\$)

OPTIONAL EXTERIOR FELT FINISHES



Tomato Red (\$\$)



Spruce Blue (\$\$)



Emerald Green (\$\$)



Navy (\$\$)

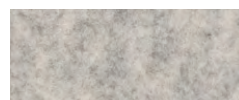

Almost White (\$\$)

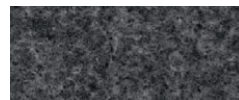

Charcoal (\$\$)



Medium Grey (\$\$)



Light Grey (\$\$)

FLOX

When you need flexible sound control

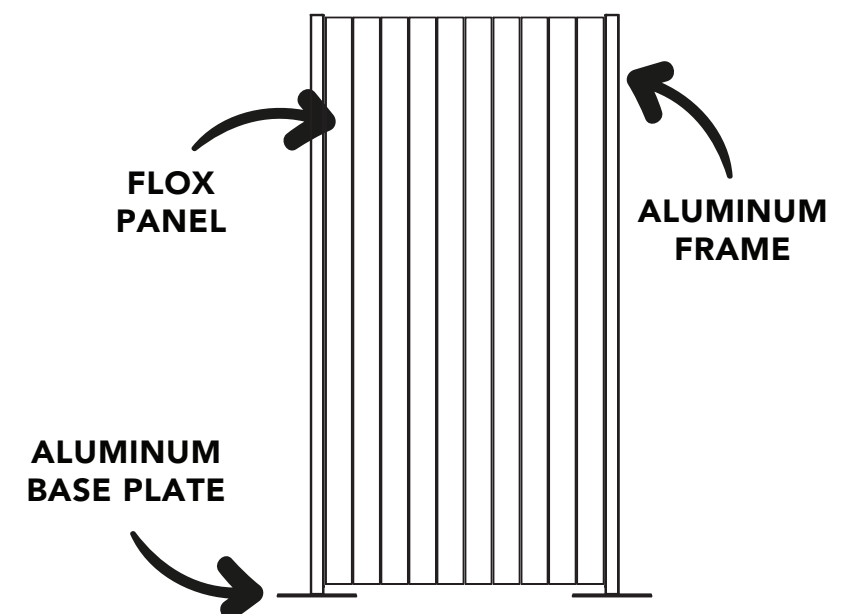

FRAME FINISHES

*Frames are made of anodized aluminum



Anodized Aluminum (\$)



Glossy White (\$\$)



Matte Black (\$\$)

BASE PLATE FINISHES

*Base plates are made of steel



Steel Silver (\$)



Glossy White (\$\$)



Matte Black (\$\$)

PANEL FINISHES

*Flox is made of premium, recycled wool blends



Ivory



Heather



Stone

DOK

When you need to define an environment

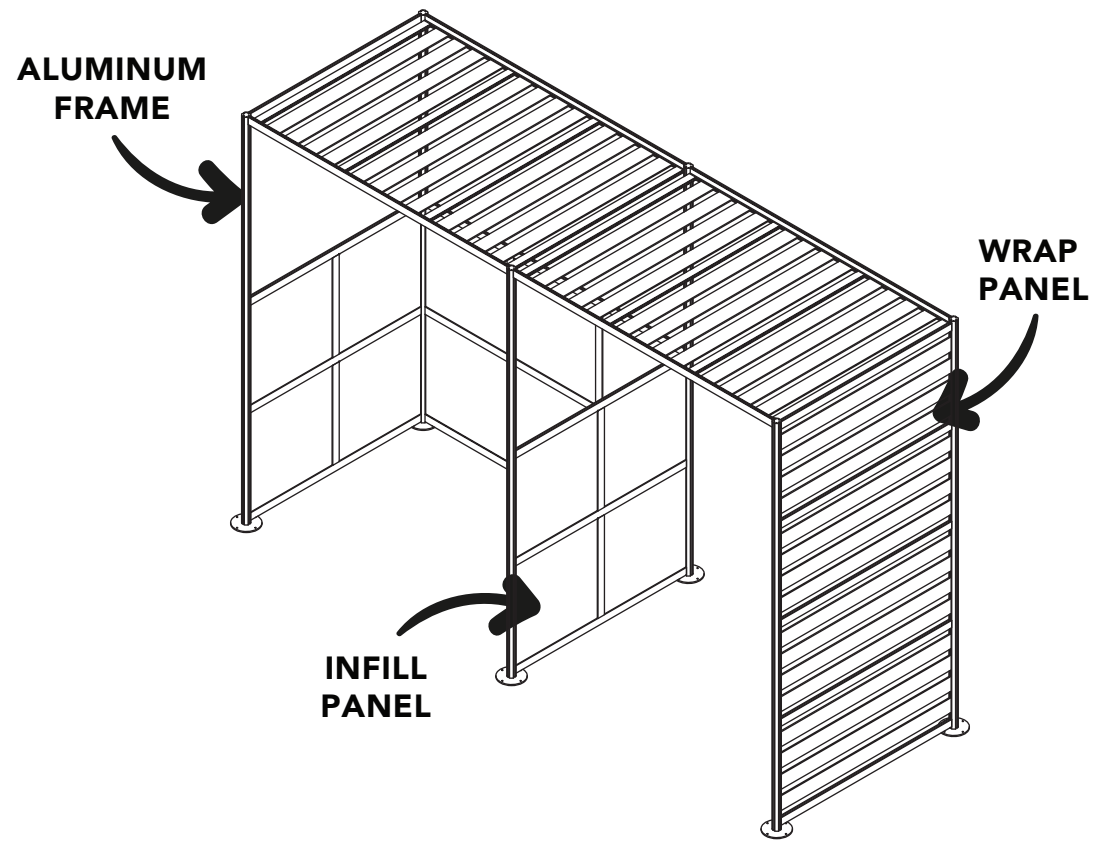

FRAME FINISHES

*Frames are made of anodized aluminum



WRAP FINISHES

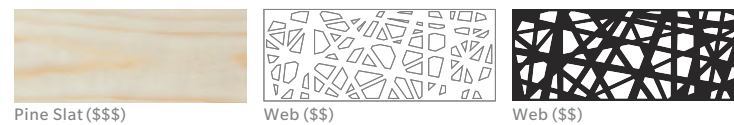

PANEL FINISHES

Laminate (\$\$)

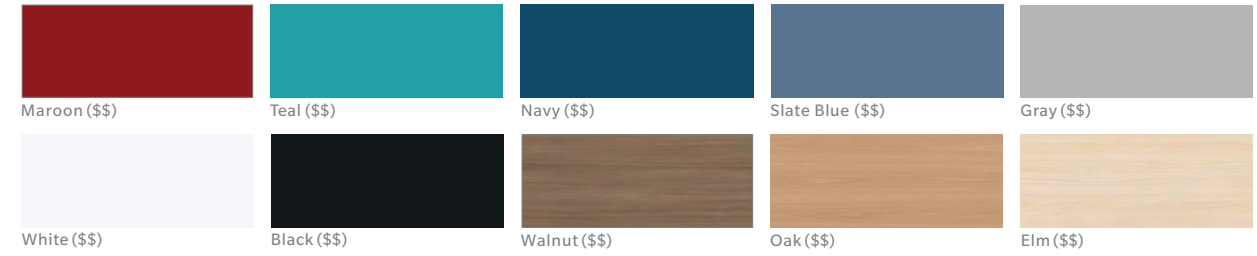

Blox (\$\$\$)

*Blox is made of premium, recycled wool blends

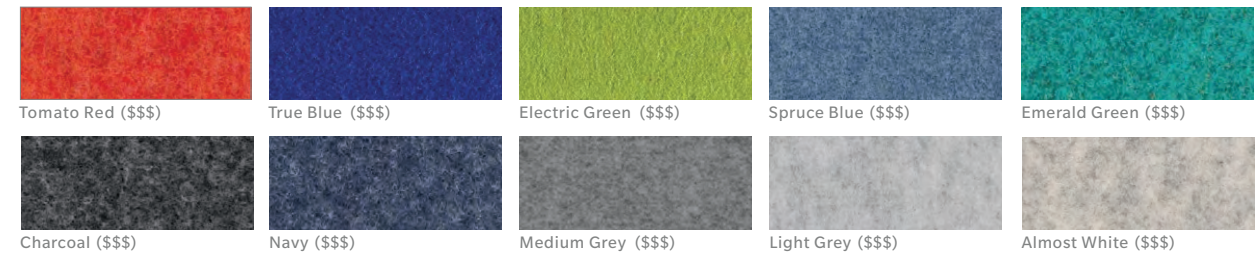

Felt (\$\$)



Akustik (\$)

*Akustik is made of recycled PET material

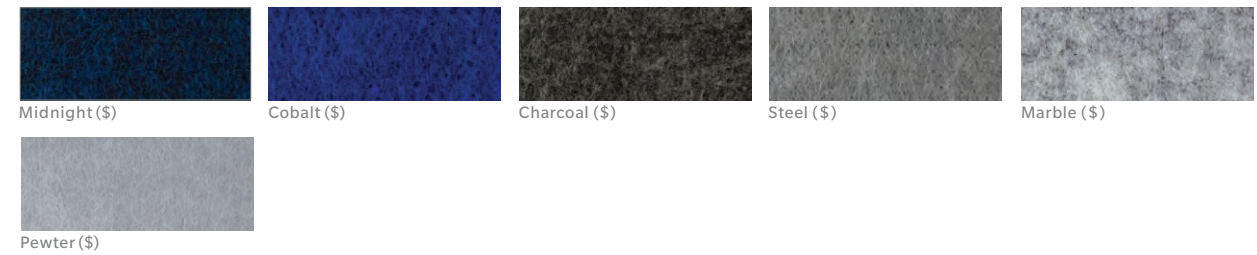

Writable (\$\$)



Translucent (\$ - \$\$)



Specialty Panel Finishes



HOVER

When full coverage privacy is needed

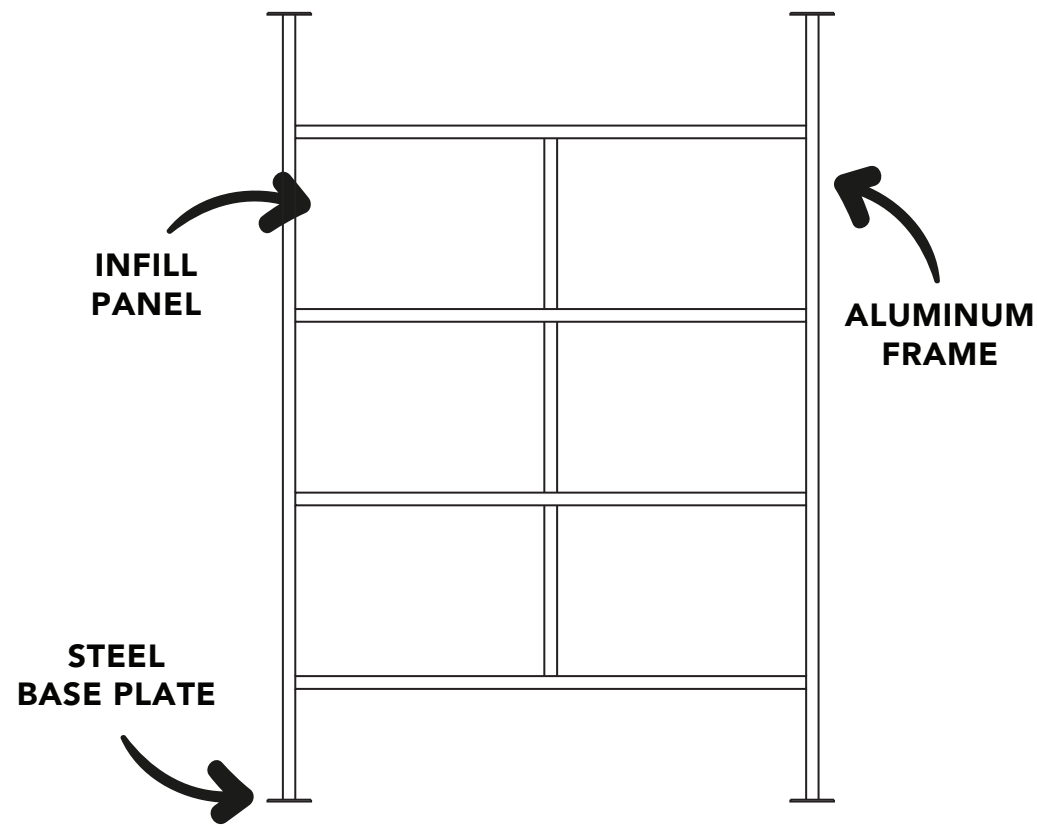

FRAME FINISHES

*Frames are made of anodized aluminum



BASE PLATE FINISHES

*Base plates are made of steel



PANEL FINISHES

Laminate (\$\$)

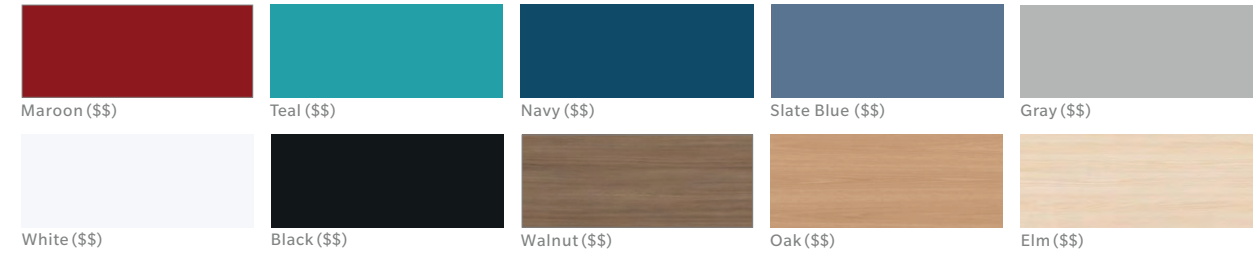

Blox (\$\$\$)

*Blox is made of premium, recycled wool blends **Only available as 2' x 4' panels

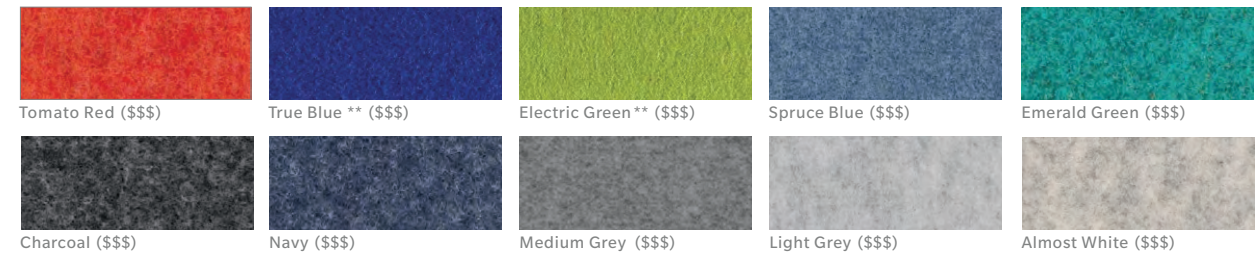

Felt (\$\$)



Akustik (\$)

*Akustik is made of recycled PET material



Writable (\$\$)



Translucent (\$ - \$\$)



Specialty Panel Finishes

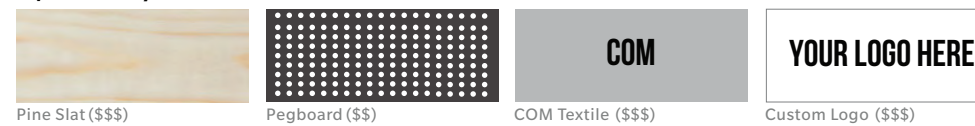

WEAVE

Wrap your space in more than just quiet

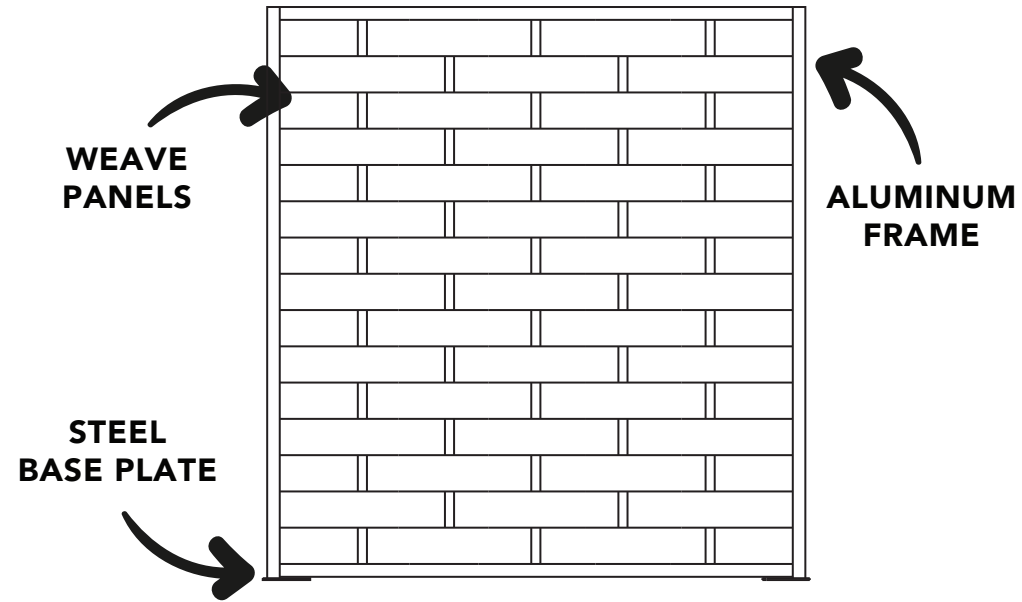

FRAME FINISHES

*Frames are made of anodized aluminum

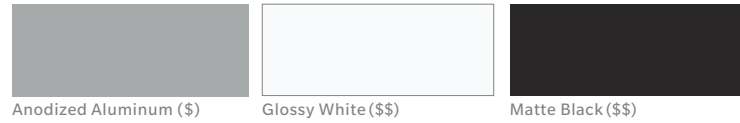

BASE PLATE FINISHES

*Base plates are made of steel



PANEL FINISHES

*Weave panels are made of recycled PET material

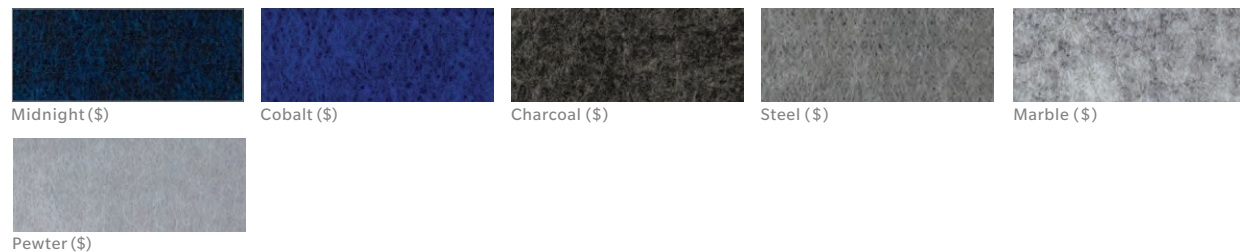

CHISEL

Decrease the noise, increase the design

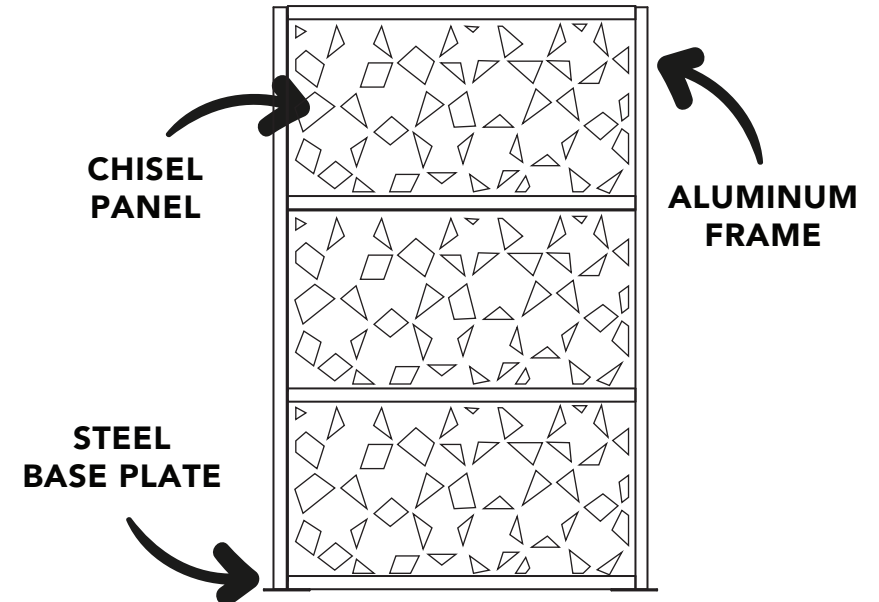

FRAME FINISHES

*Frames are made of anodized aluminum

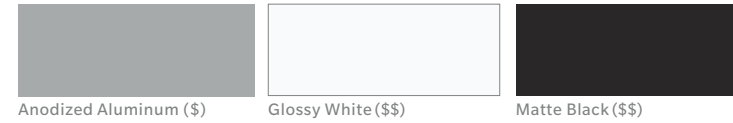

BASE PLATE FINISHES

*Base plates are made of steel

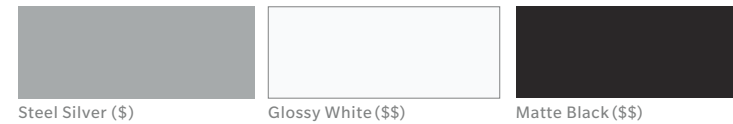

PANEL FINISHES

*Chisel panels are made of recycled PET material

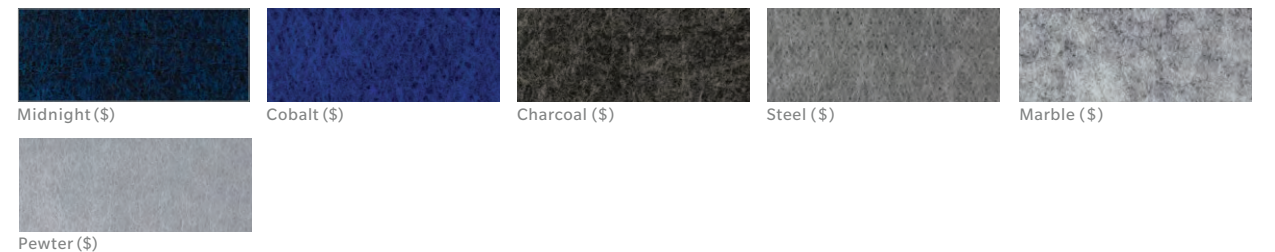

WEB

When you need to let some light in

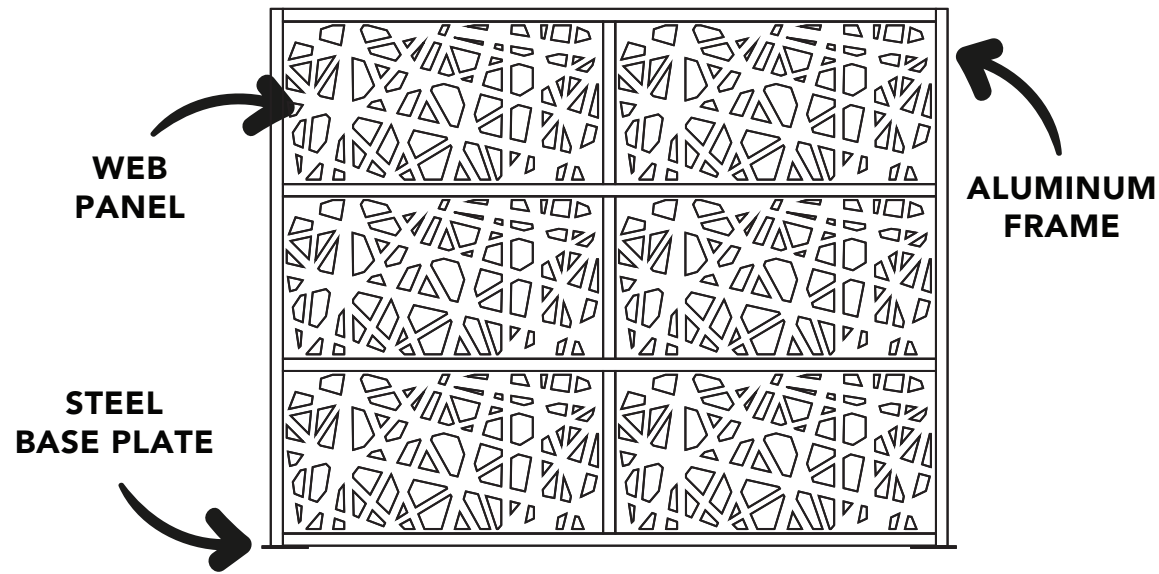

FRAME FINISHES

*Frames are made of anodized aluminum



BASE PLATE FINISHES

*Base plates are made of steel



PANEL FINISHES

*Web panels are made from high-density polyethylene

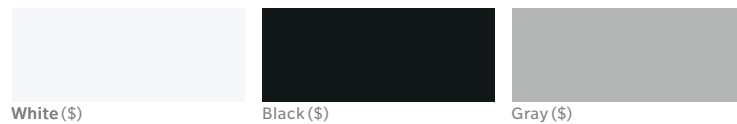

WAVE

Divide a space and add some texture

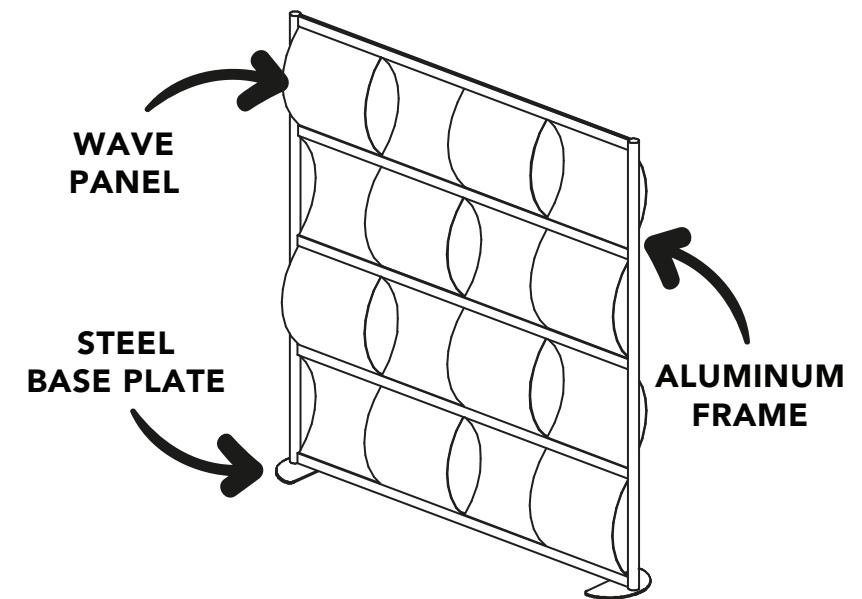

FRAME FINISHES

*Frames are made of anodized aluminum



BASE PLATE FINISHES

*Base plates are made of steel



PANEL FINISHES

*Wave panels are made from polyvinyl chloride

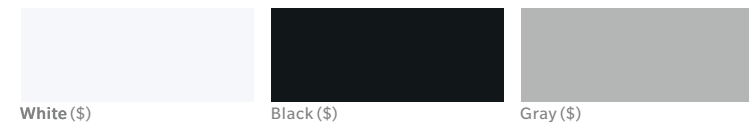

BLOX

Turn down the world's volume

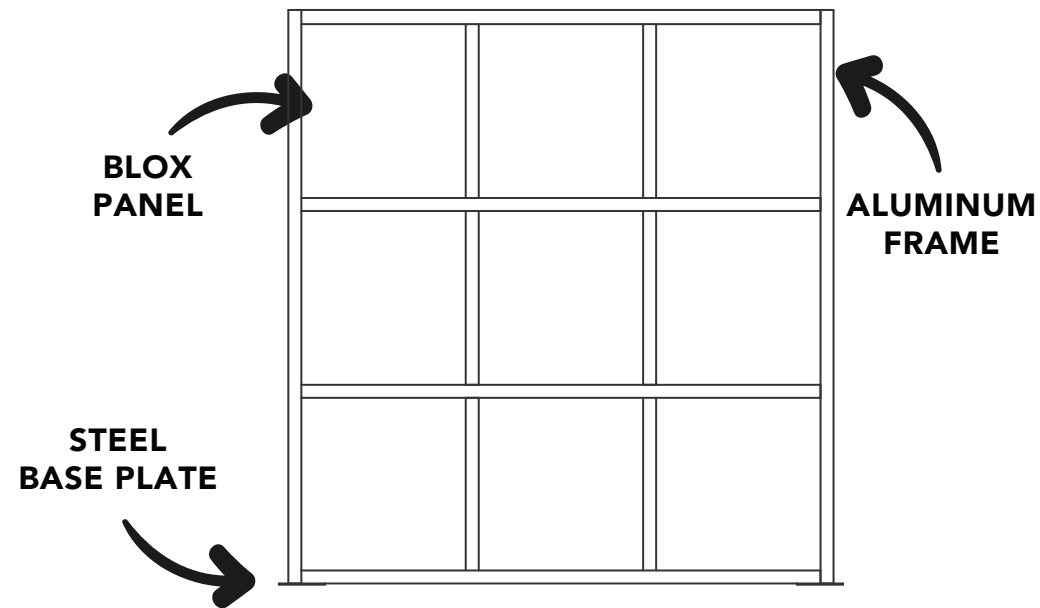

FRAME FINISHES

*Frames are made of anodized aluminum



BASE PLATE FINISHES

*Base plates are made of steel



PANEL FINISHES

*Blox is made of premium, recycled wool blends **Only available as 2' x 4' panels

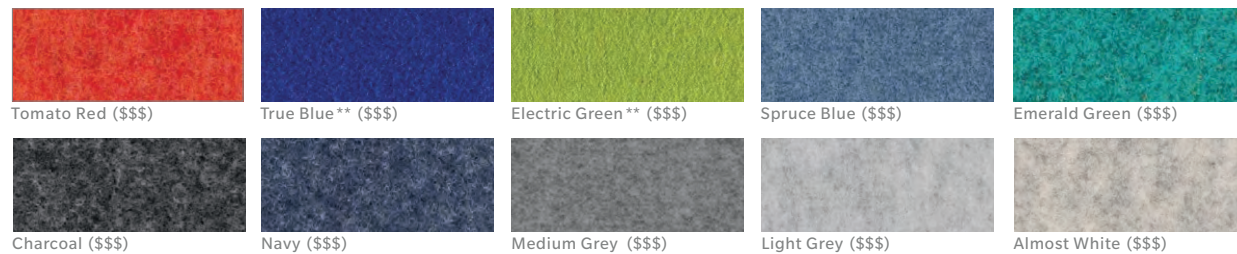

COM PARTNERS

Looking for something specific? Check out some of our C.O.M. partners!



EMAIL QUOTES@LOFTWALL.COM
TO GET STARTED!