

# GRAVITY

## ceiling mounting

**Warning** It is important to utilize the correct screws for each corresponding ceiling and floor surface. Screws are not provided. Screws should be able to support 40 lbs of weight.

### Tools

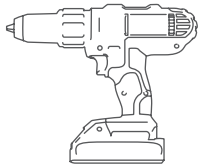

**Power Drill**  
(Not Included)

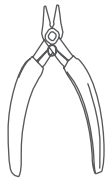

**Wire Cutters**  
(Not Included)



**Crimper**  
(Not Included)

### Product Specs

Height: 68.75" (3 Quarters) or 91.5" (Full)

Width: 46"

Depth: 0.25" (All) or 0.5" ( Select Finishes)

**Location of Holes:** 11" from edge and 24" between each other.

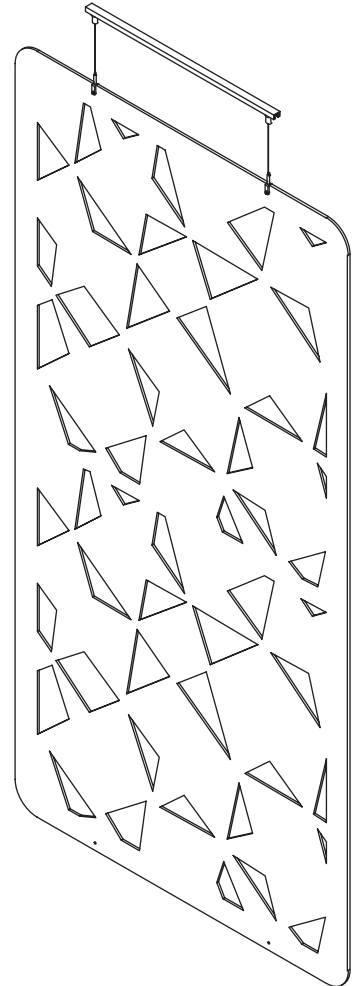
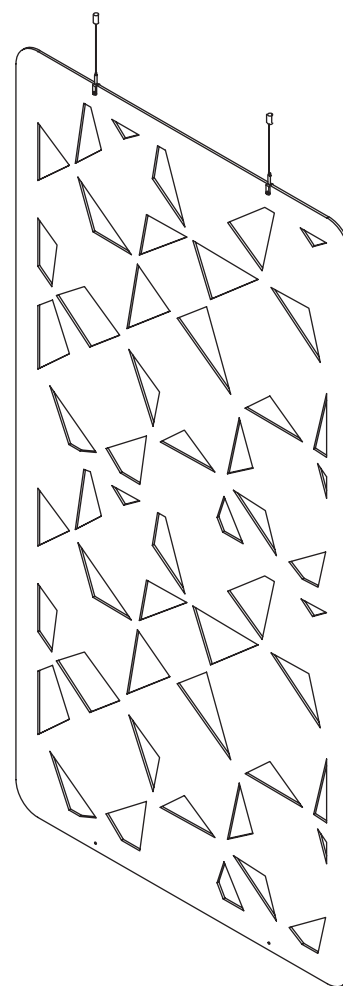
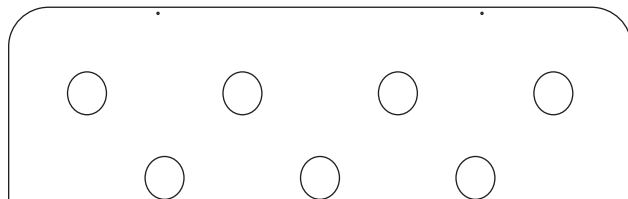

# Gravity ceiling coupler assembly

## Parts List

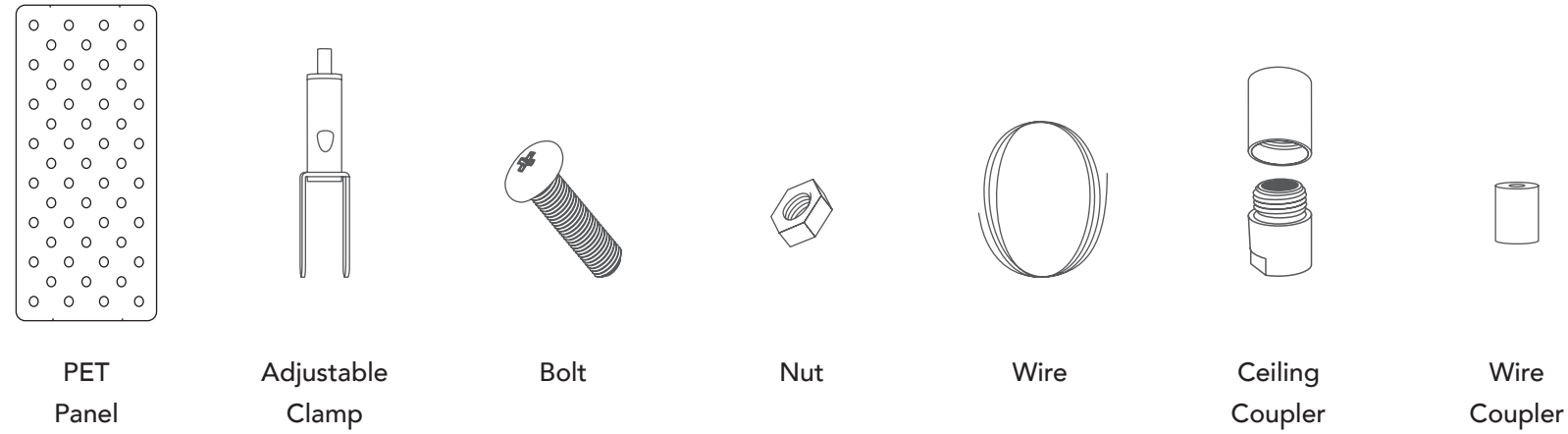

**Step 1** Using a bolt and nut, attach an adjustable clamp to the Gravity panel using the precut holes. Repeat this process one more time to complete step 1.

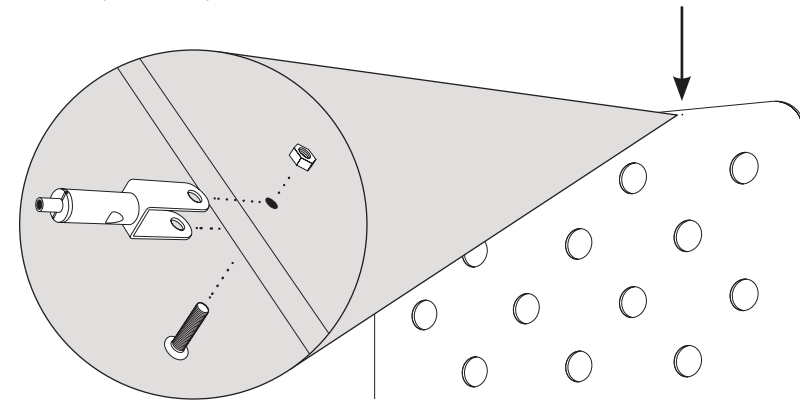

**Step 2** Before cutting wire, determine the desired length and add 2-3 more inches; this will allow wiggle room for hanging. Cut the wire to the desired length making sure the wire lengths match.

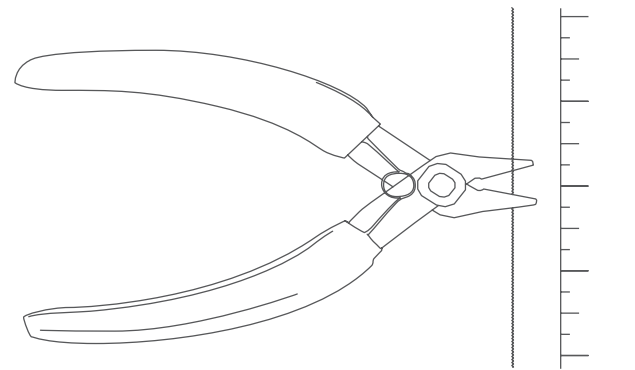

**Step 3** Using the cut wire slide one end through the top of the clamp. To adjust the wire push down on the top of the clamp and pull the wire to its desired length. Do not cut any wire at this point in the process.

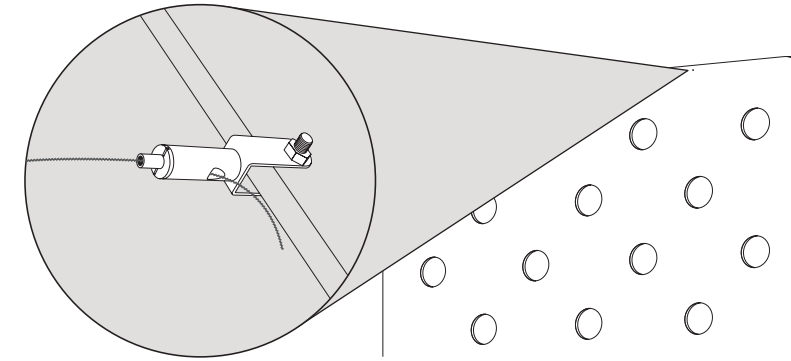

**Step 4** Slide the bottom half of the ceiling coupler onto the wire, making sure the threaded side is facing away from the panel. Crimp the wire coupler to the end of the wire. Repeat

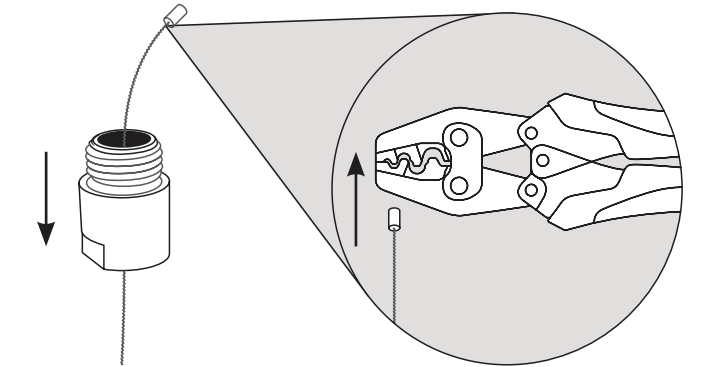

**Step 5** Using a drill attach the upper half of the ceiling coupler to the ceiling using appropriate screws for your ceiling. There is 11" from the edge of the panel to the center of the coupler and 24" between each coupler.

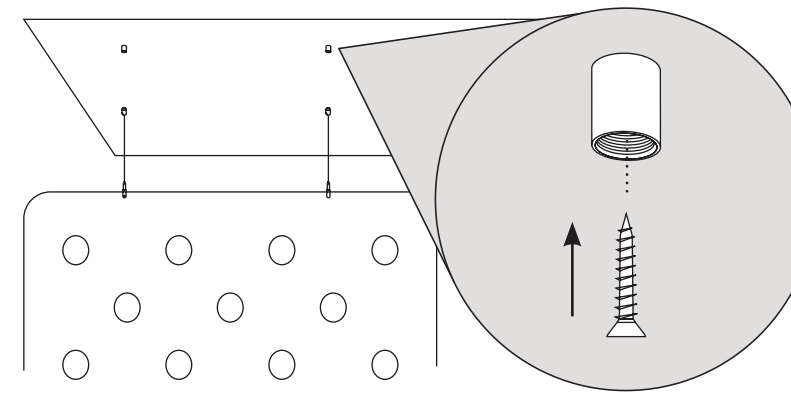

**Step 6** Raise the panel and all attached parts to the ceiling and screw the bottom half of the ceiling coupler into the top half.

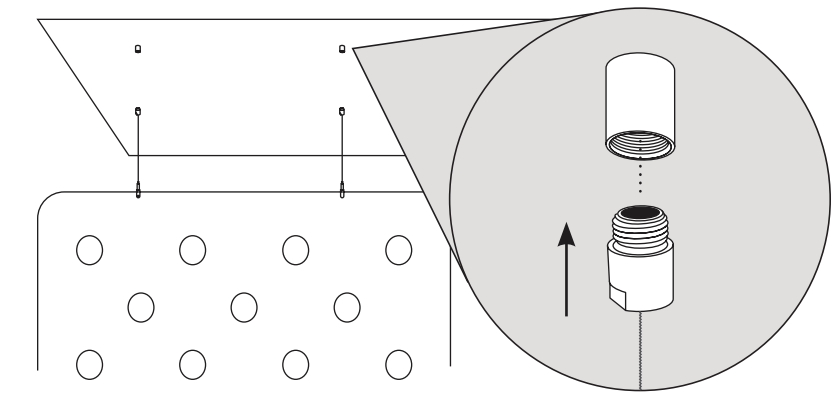

# Gravity ceiling track assembly

## Parts List

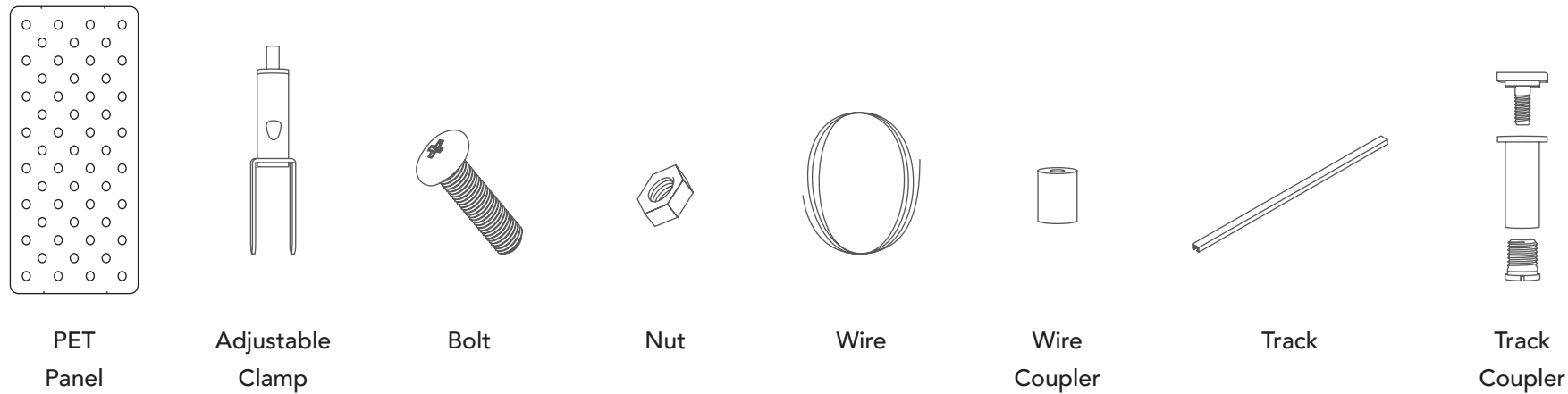

**Step 1** Using a bolt and nut, attach an adjustable clamp to the Gravity panel using the precut holes. Repeat this process one more time to complete step 1.

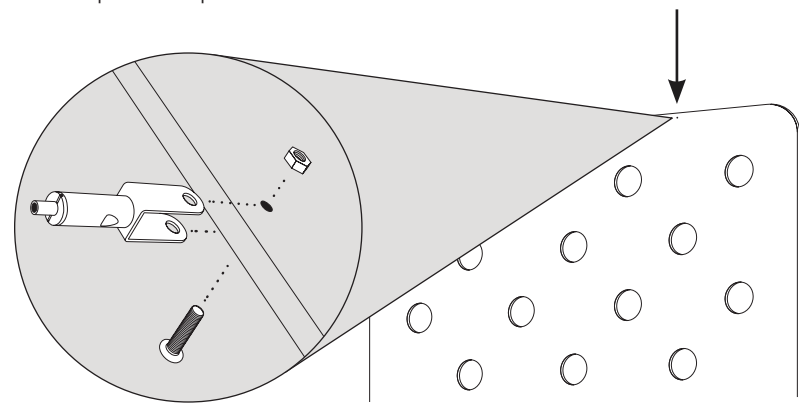

**Step 2** Before cutting wire, determine the desired length and add 2-3 more inches; this will allow wiggle room for hanging. Cut the wire to the desired length making sure the wire lengths match.

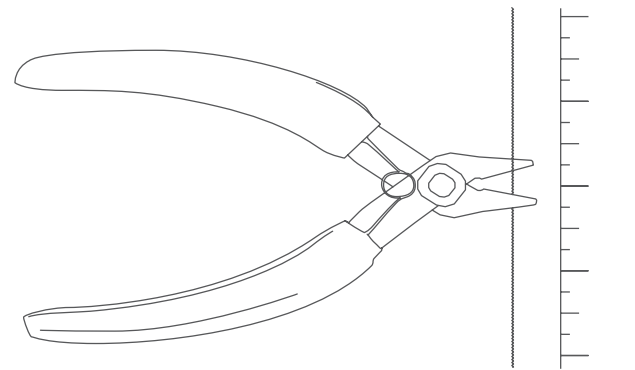

**Step 3** Using the cut wire slide one end through the top of the clamp. To adjust the wire push down on the top of the clamp and pull the wire to its desired length. Do not cut any wire at this point in the process.

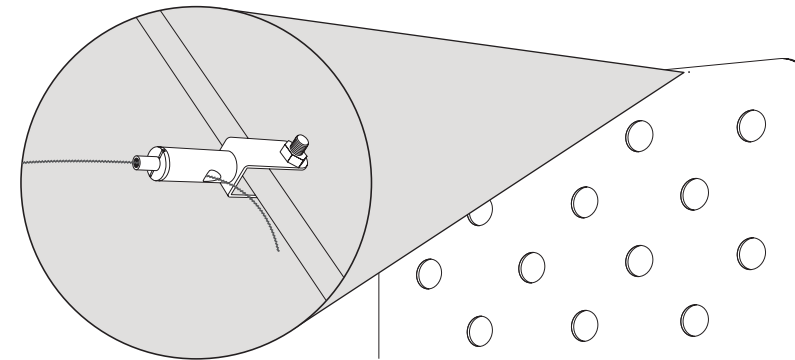

**Step 4** Slide the bottom half of the track coupler onto the wire, making sure the threaded side is facing away from the panel. Using a crimper, crimp the wire coupler to the end of the wire. Repeat process.

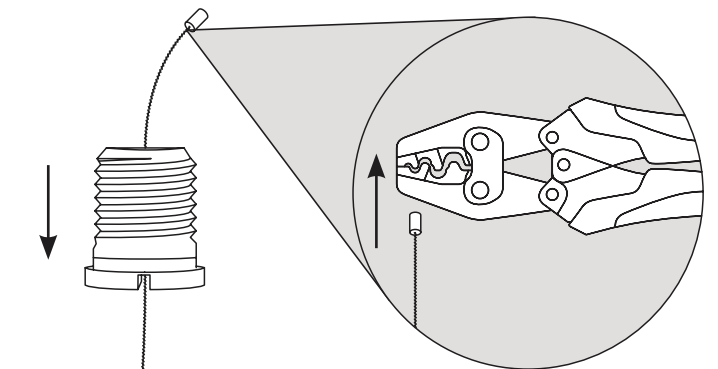

**Step 5** Screw on the middle component of the track coupler to the bottom component attached to the wire. Then screw on the top component of the track coupler.

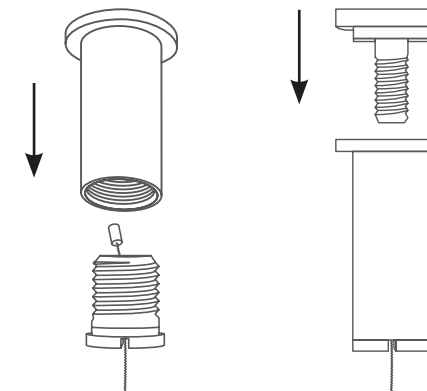

**Step 6** Using a drill, attach the track to the ceiling keeping in mind that the panel will hang just below it. Be sure to use screws appropriate for your ceiling material.

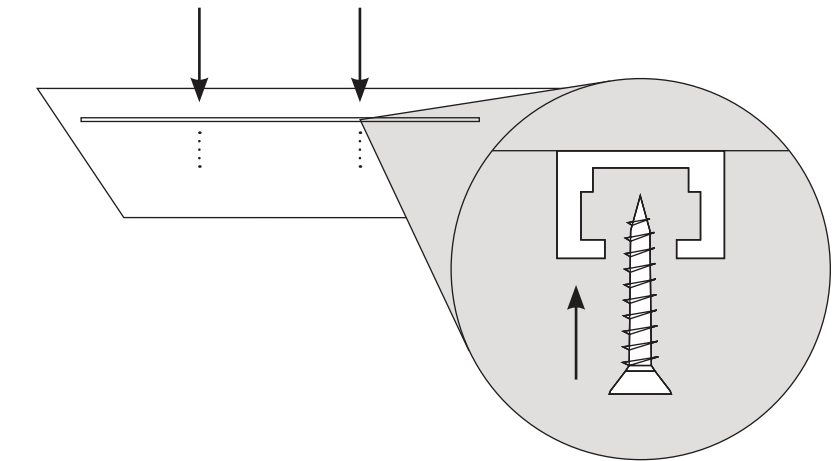

### Step 7

Using the cut wire slide one end through the top of the clamp. To adjust the wire push down on the top of the clamp and pull the wire to its desired length. Do not cut any wire at this point in the process.

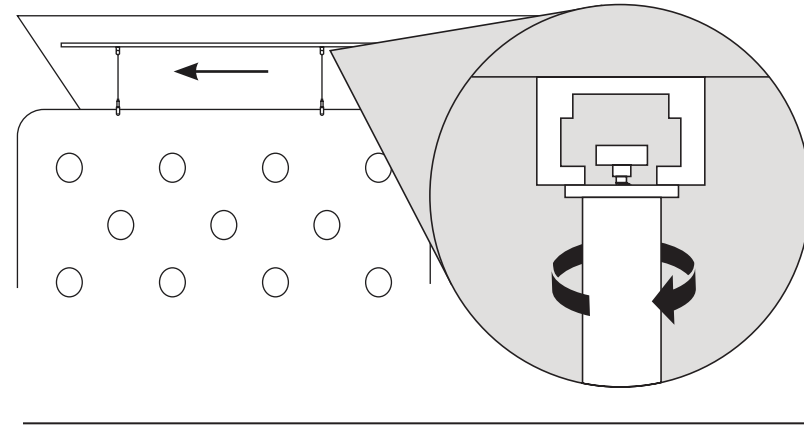

# GRAVITY

## floor mounting

### Tools

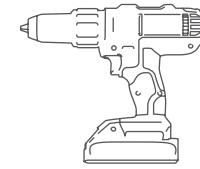

Power Drill  
(Not Included)



Wire Cutters  
(Not Included)



Crimper  
(Not Included)

### Product Specs

Height: 68.75" (3 Quarters) or 91.5" (Full)

Width: 46"

Depth: 0.25" (All) or 0.5" ( Select Finishes)

Location of Holes: 11" from edge and 24" between each other.

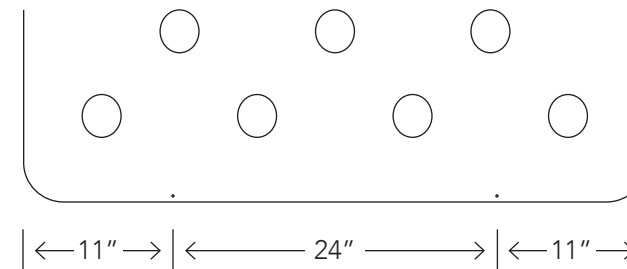

### Warning

It is important to utilize the correct screws for each corresponding ceiling and floor surface. Screws are not provided. Screws should be able to support 40 lbs of weight.

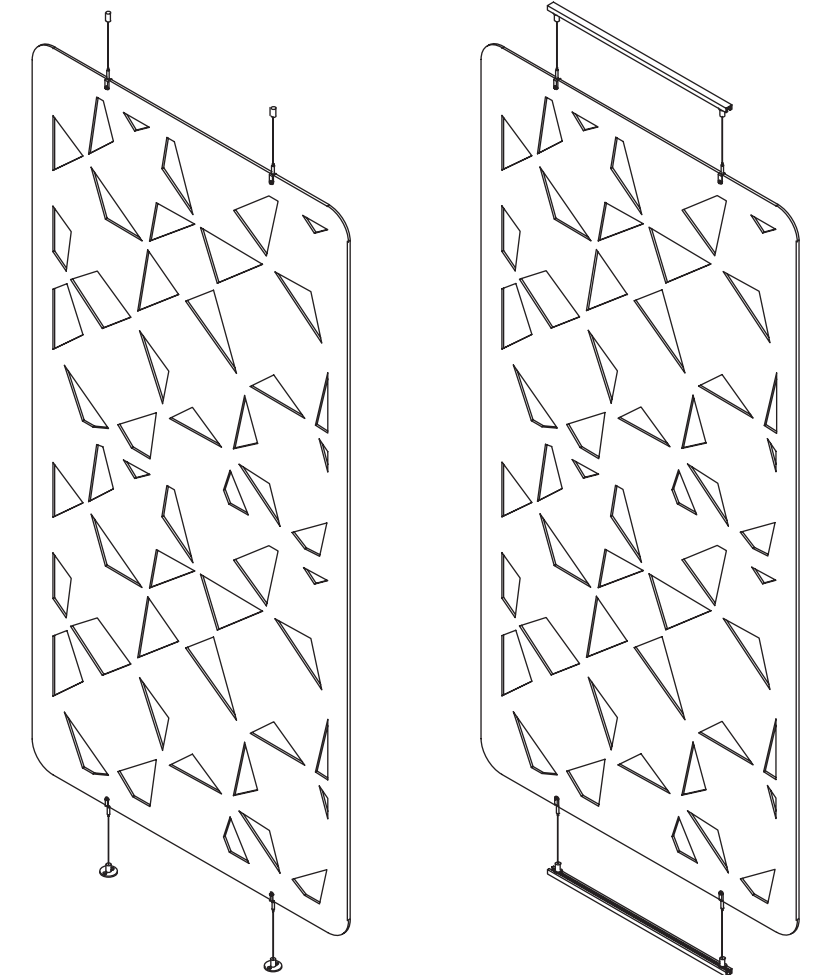

# Gravity floor mount assembly

## Parts List

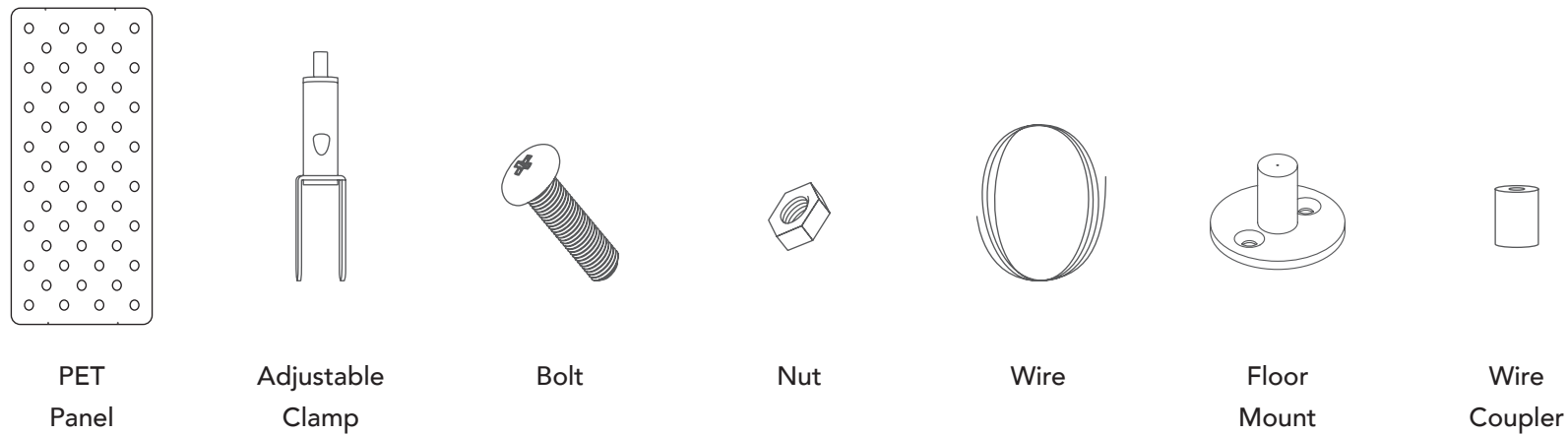

**Step 1** Using a bolt and nut, attach an adjustable clamp to the Gravity panel using the precut holes.

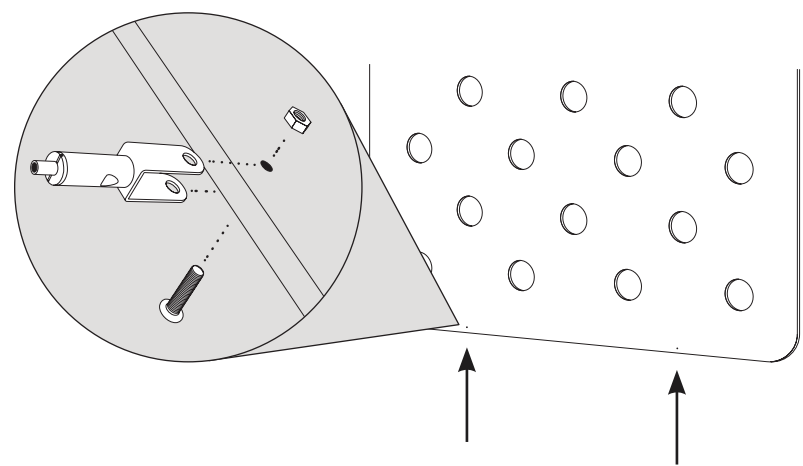

**Step 2** Before cutting wire, determine the desired length and add 2-3 more inches; this will allow wiggle room for hanging. Using a wire cutter, cut the wire to the desired length making sure the wire lengths match.

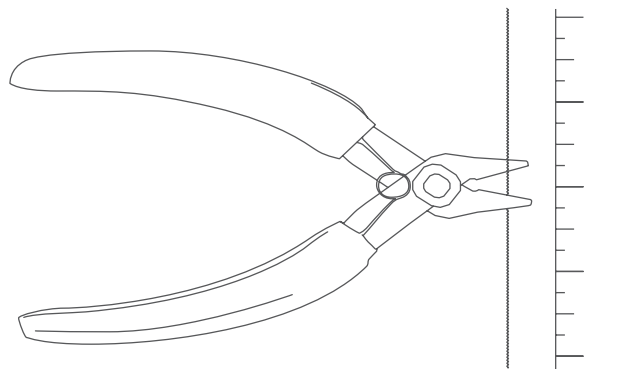

**Step 3** Using the cut wire slide one end through the top of the clamp. To adjust the wire push down on the top of the clamp and pull the wire to its desired length. Do not cut any wire at this point in the process.

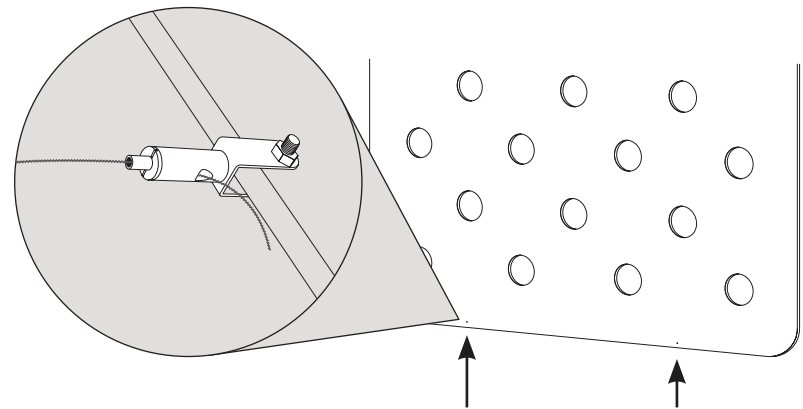

**Step 4** Slide the floor mount onto the wire, making sure the larger flat end is facing away from the floor. Using a crimper, crimp the wire coupler to the end of the wire.

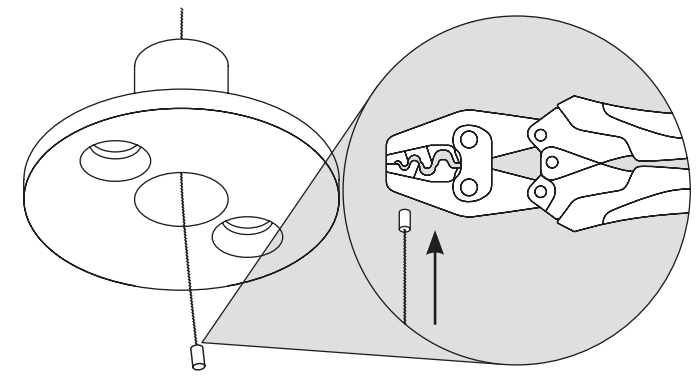

**Step 5** Line up the floor mounts with the adjustable clamp so that the wire hangs vertically, then using a drill, screw the floor mount to the floor using the appropriate screws for your floor.

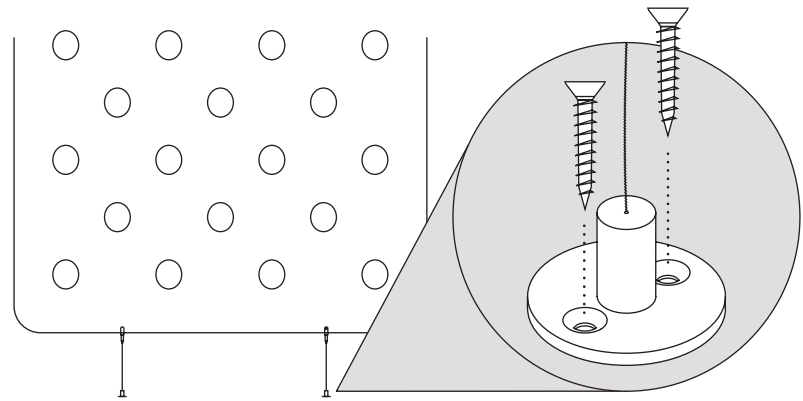

# Gravity floor track assembly

## Parts List

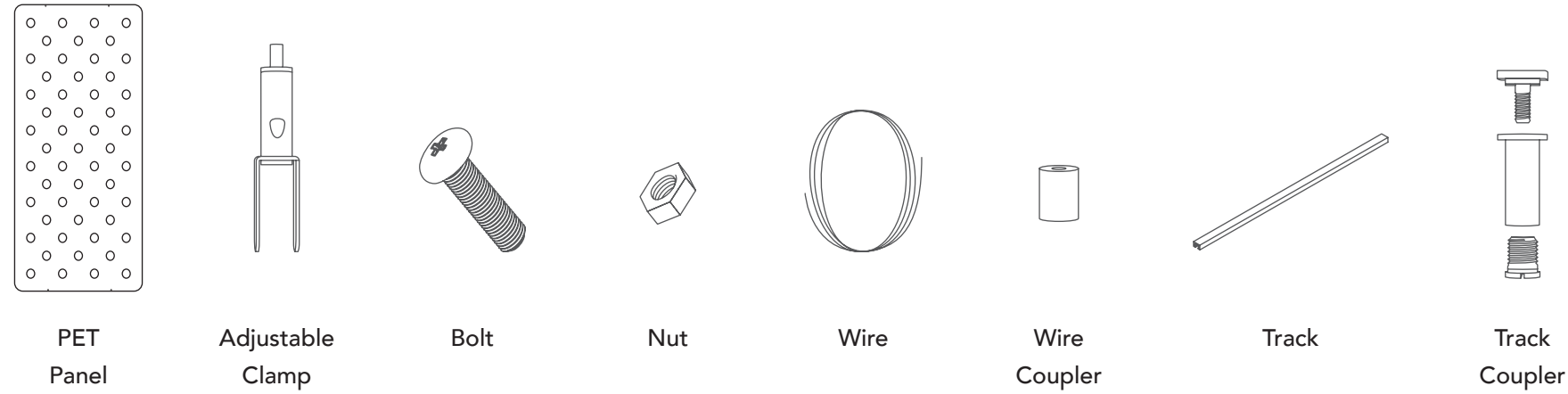

**Step 1** Using a bolt and nut, attach an adjustable clamp to the Gravity panel using the precut holes.

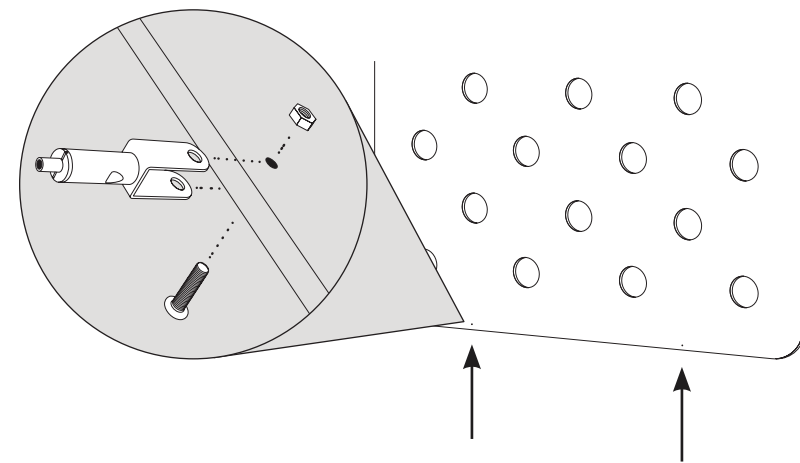

**Step 2** Before cutting wire, determine the desired length and add 2-3 more inches; this will allow wiggle room for hanging. Using wire cutters, cut the wire to the desired length making sure the wire lengths match.

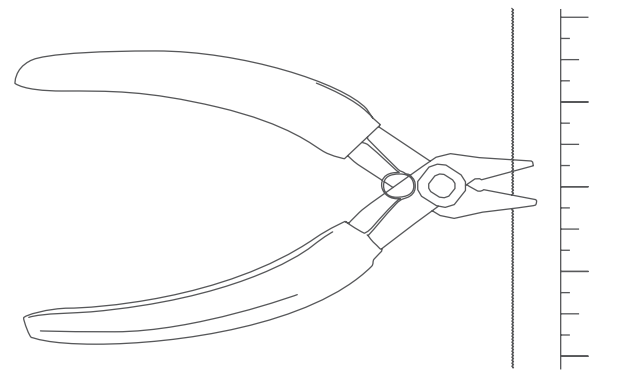

**Step 3** Using the cut wire slide one end through the top of the clamp. To adjust the wire push down on the top of the clamp and pull the wire to its desired length. Do not cut any wire at this point in the process.

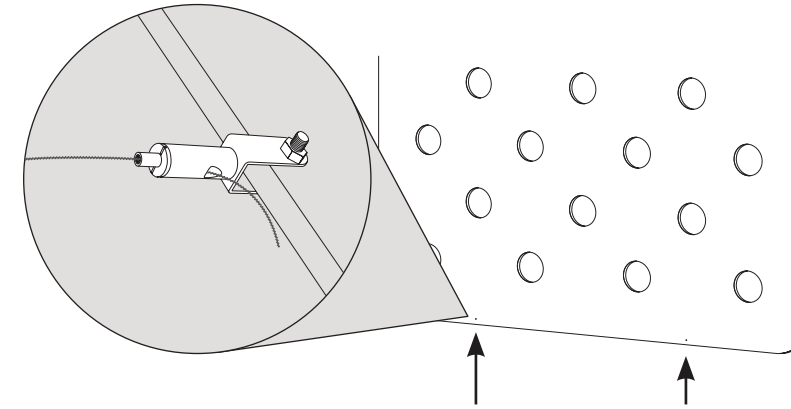

**Step 4** Slide the bottom half of the track coupler onto the wire, making sure the threaded side is facing away from the panel. Using a crimper, crimp the wire coupler to the end of the wire.

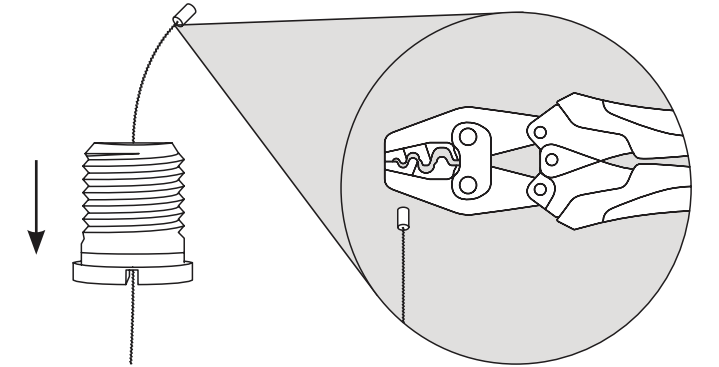

**Step 5** Screw on the middle component of the track coupler to the bottom component attached to the wire. Then screw on the top component of the track coupler.

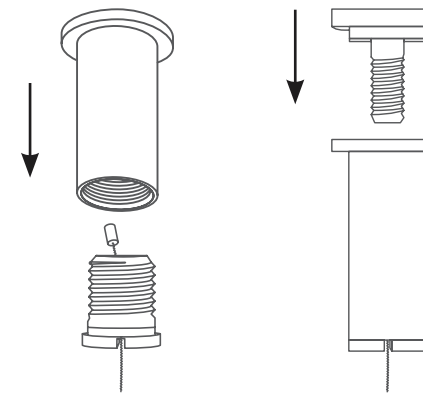

**Step 6** Using a drill, attach the track to the floor keeping in mind that the panel will hang just above it. Be sure to use screws appropriate for your floor material.

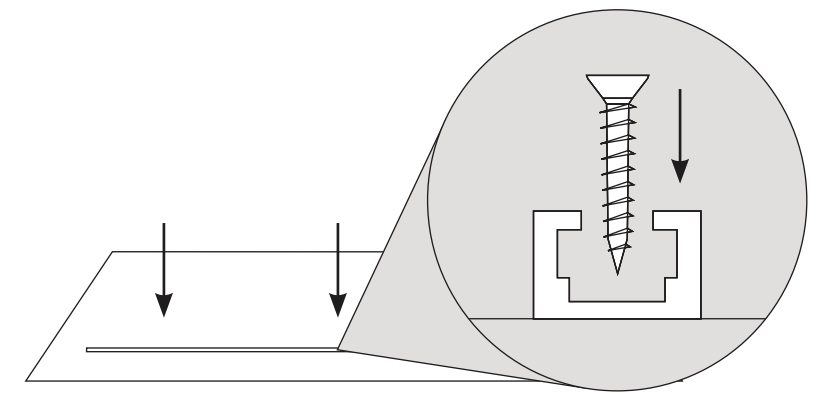

**Step 7**

Slide the track couplers into the track. Position the couplers so the wires hang vertically. Tighten the track coupler by twisting the center component against the track.

