

THIN

ceiling mounting

Tools

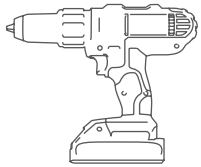

Power Drill
(Not Included)

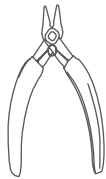

Wire Cutters
(Not Included)



Crimper
(Not Included)

Product Styles

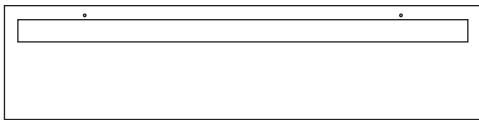

Base

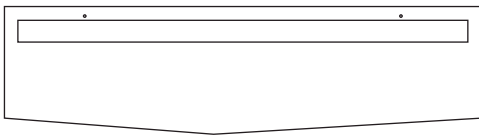

Pitch

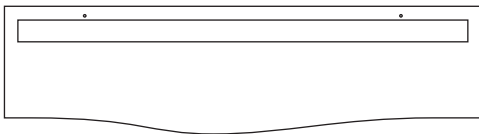

Wave

Warning

It is important to utilize the correct screws for each corresponding ceiling and floor surface. Screws are not provided. Screws should be able to support 40 lbs of weight.

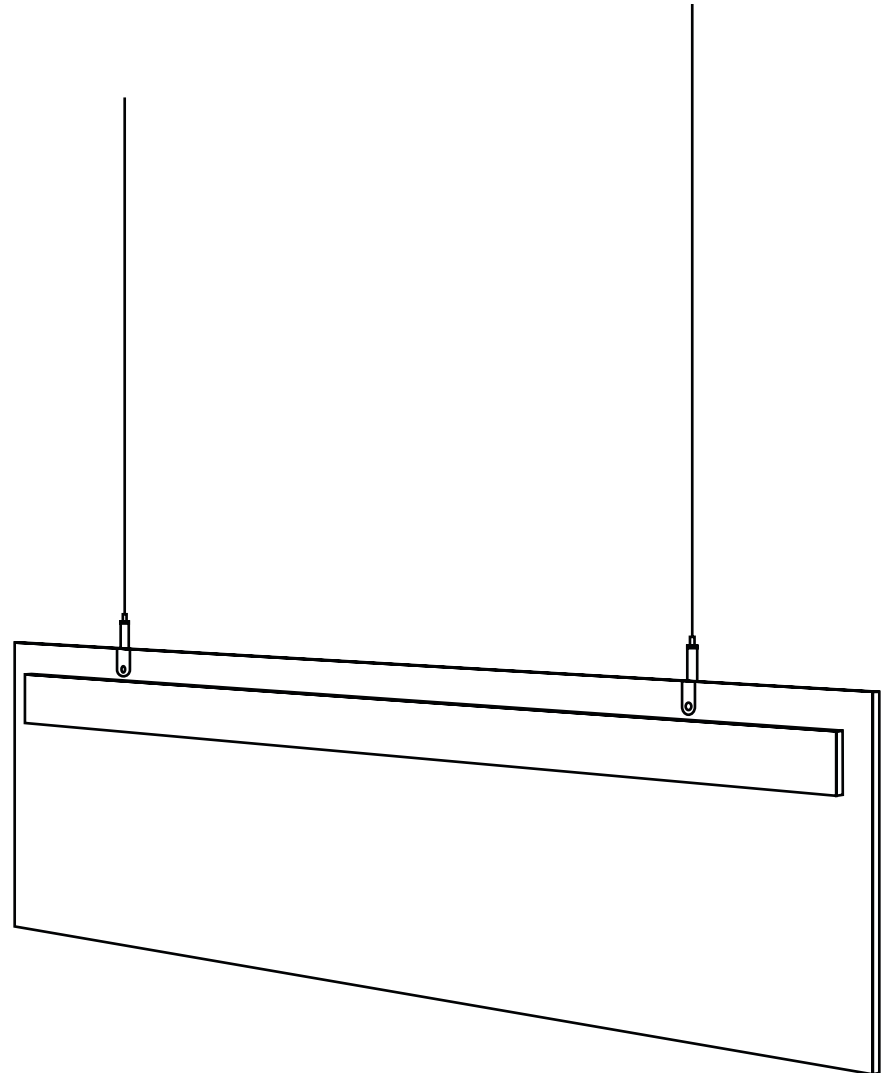

Thin ceiling coupler assembly

Parts List



Baffle



Adjustable
Clamp

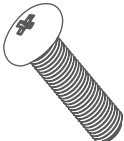

Bolt



Nut

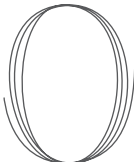

Wire



Ceiling
Coupler



Wire
Coupler

Step 1

Using a bolt and nut, attach an adjustable clamp to the Thin baffle using the precut holes. Repeat this process one more time to complete step 1.

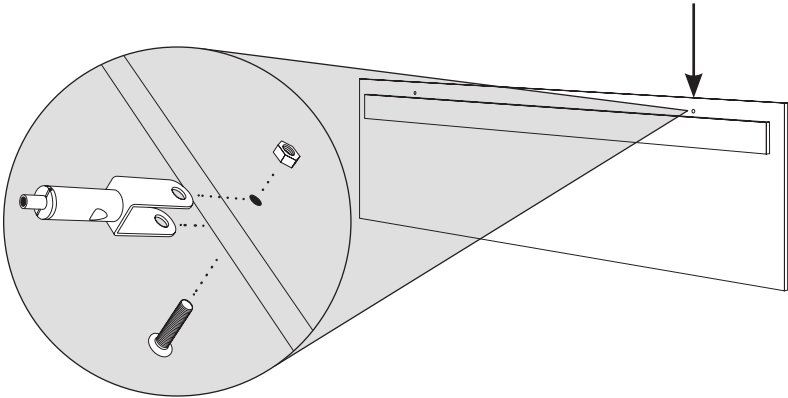

Step 2

Before cutting wire, determine the desired length and add 2-3 more inches; this will allow wiggle room for hanging. Cut the wire to the desired length making sure the wire lengths match.

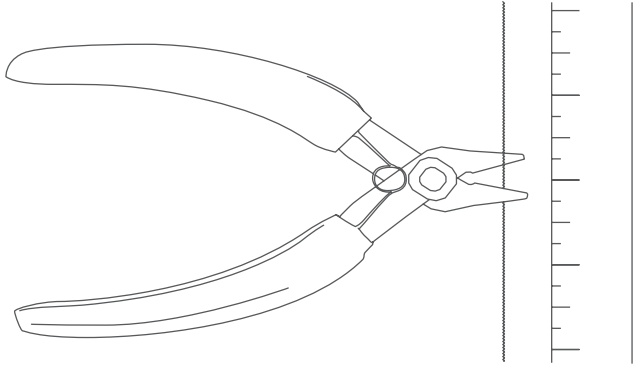

Step 3 Using the cut wire, slide one end through the top of the clamp. To adjust the wire push down on the top of the clamp and pull the wire to its desired length. Do not cut any wire at this point in the process.

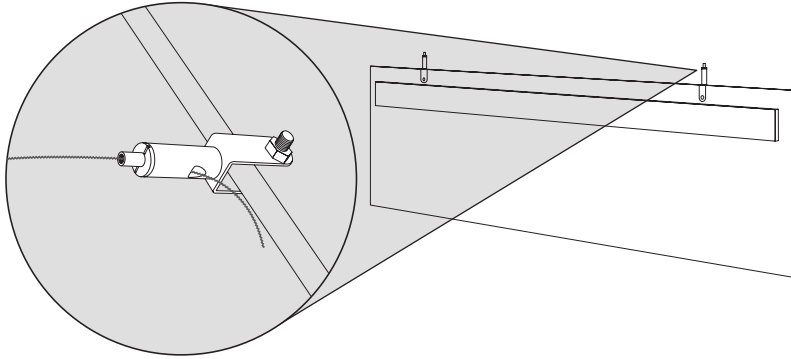

Step 4 Slide the bottom half of the ceiling coupler onto the wire, making sure the threaded side is facing away from the panel. Crimp the wire coupler to the end of the wire. Repeat

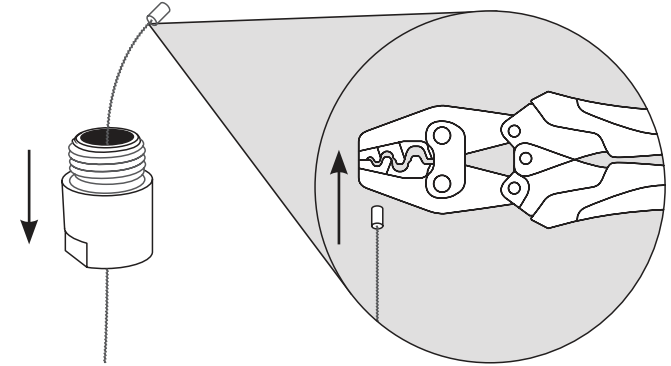

Step 5 Using a drill attach the upper half of the ceiling coupler to the ceiling using appropriate screws for your ceiling. There is 31.5" between each clamp.

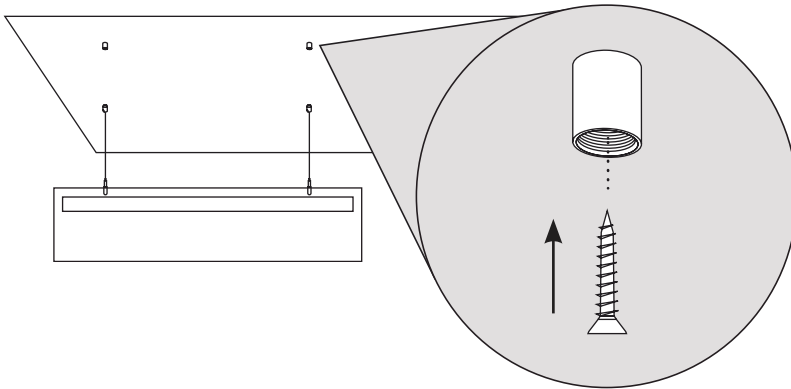

Step 6 Raise the baffle and all attached parts to the ceiling and screw the bottom half of the ceiling coupler into the top half.

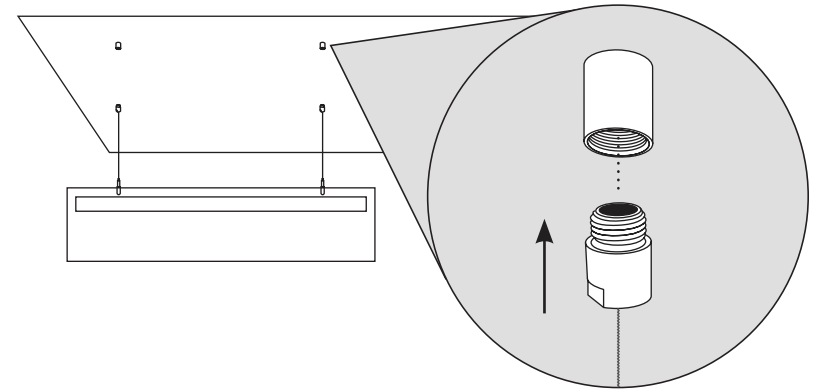

Thin ceiling track assembly

Parts List

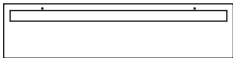

Baffle

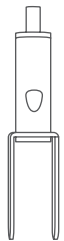

Adjustable
Clamp

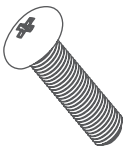

Bolt



Nut

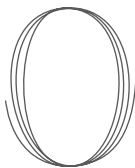

Wire



Wire
Coupler

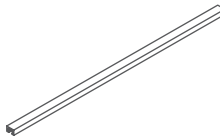

Track



Track
Coupler

Step 1

Using a bolt and nut, attach an adjustable clamp to the baffle panel using the precut holes.

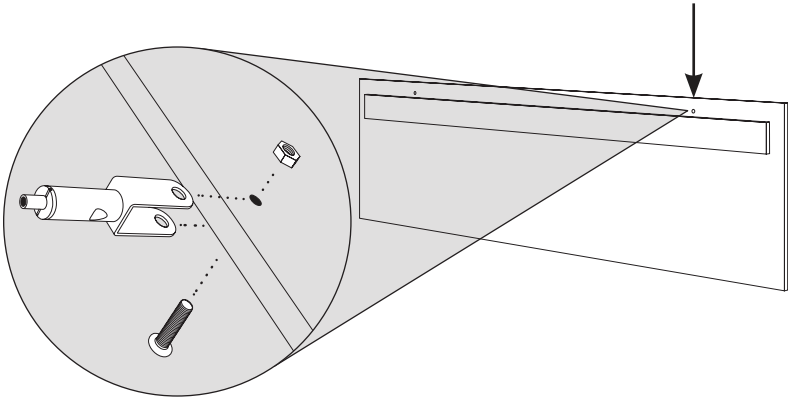

Step 2

Before cutting wire, determine the desired length and add 2-3 more inches; this will allow wiggle room for hanging. Using wire cutters, cut the wire to the desired length making sure the wire lengths match.

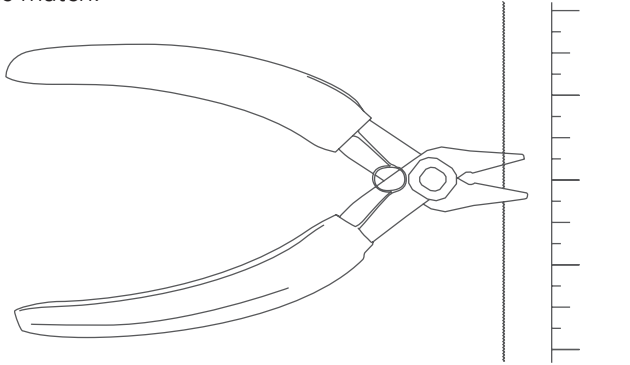

Step 3 Using the cut wire slide one end through the top of the clamp. To adjust the wire push down on the top of the clamp and pull the wire to its desired length. Do not cut any wire at this point in the process.

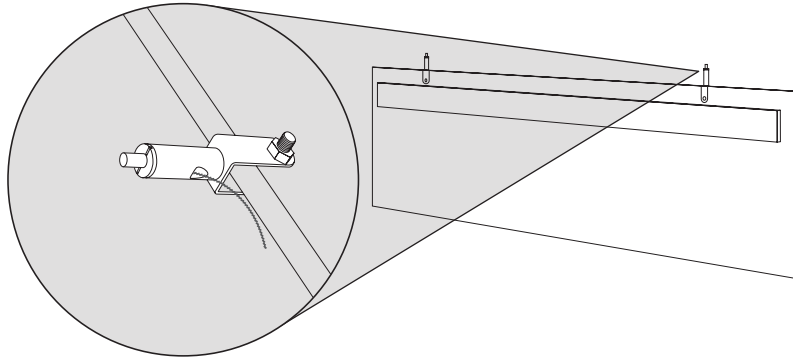

Step 4 Using a drill, attach the track to the ceiling keeping in mind that the panel will hang just below it. Be sure to use screws appropriate for your ceiling material.

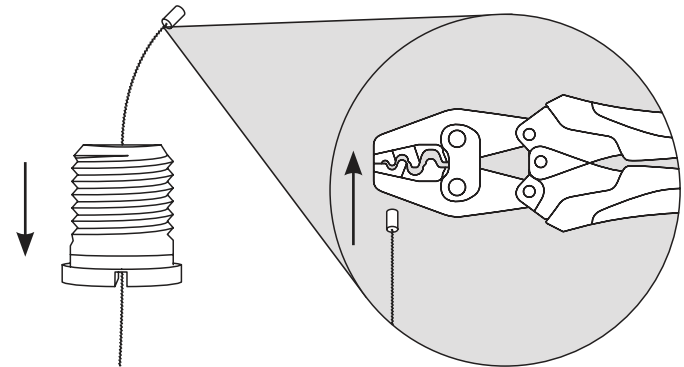

Step 5 Screw on the middle component of the track coupler to the bottom component attached to the wire. Then screw on the top component of the track coupler.

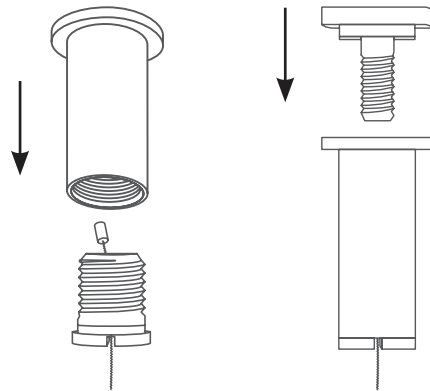

Step 6 Using a drill, attach the track to the ceiling keeping in mind that the panel will hang just below it. Be sure to use screws appropriate for your ceiling material. If you are hanging multiple baffles, you can also attach two tracks perpendicular to the baffles. Note that the distance between each coupler is 31.5".

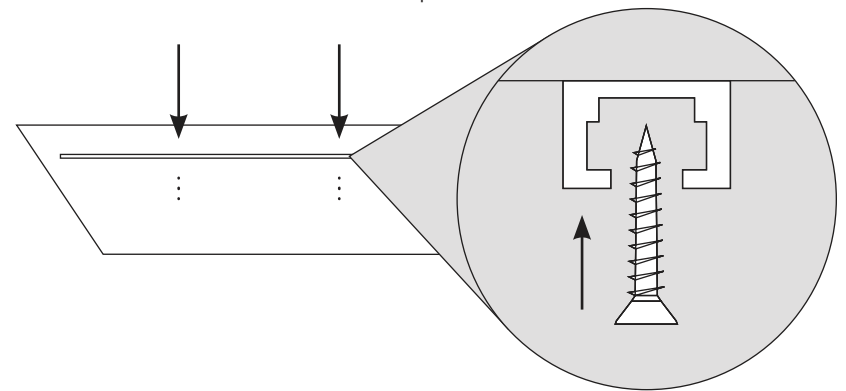

Step 7

Raise the panel and attached components and slide the track couplers into the track. Position the couplers so the wires hang vertically. Tighten the track coupler by twisting the center component against the track.

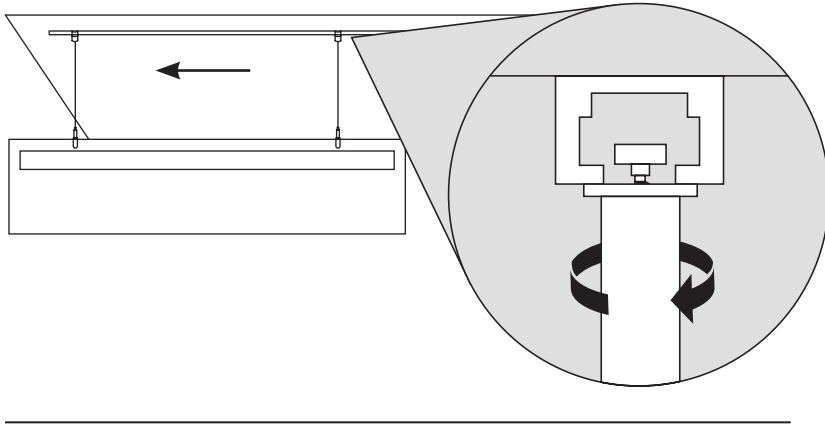

Thin unistrut channel track assembly

Parts List

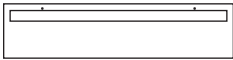

Baffle

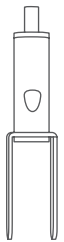

Adjustable
Clamp

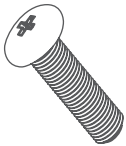

Bolt



Nut

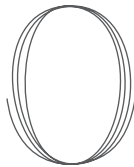

Wire

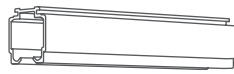

Unistrut
*not included



Coupler
Component

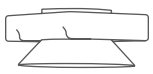

Unistrut
Insert

OUR UNISTRUT INSERTS
ARE ONLY COMPATIBLE
WITH TRACKS THAT ARE
1.625" WIDE AND AT LEAST
1" TALL

Step 1

Using a bolt and nut, attach an adjustable clamp to the baffle panel using the precut holes.

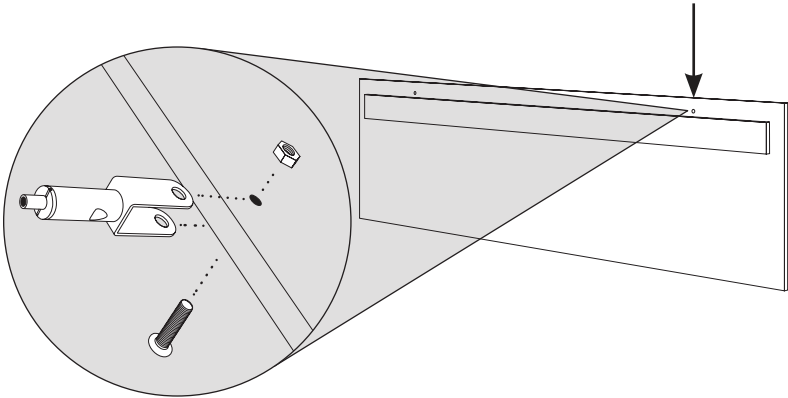

Step 2

Before cutting wire, determine the desired length and add 2-3 more inches; this will allow wiggle room for hanging. Using wire cutters, cut the wire to the desired length making sure the wire lengths match.

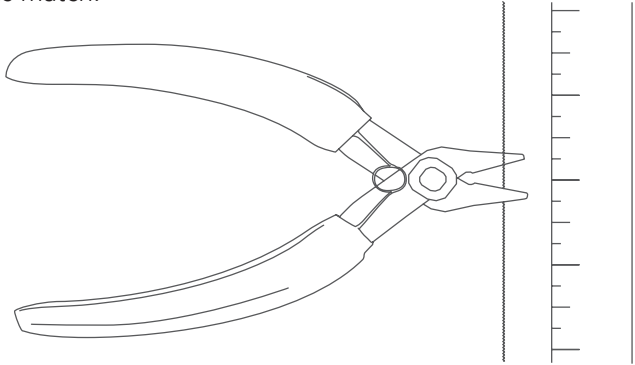

Step 3 Using the cut wire slide one end through the top of the clamp. To adjust the wire push down on the top of the clamp and pull the wire to its desired length. Do not cut any wire at this point in the process.

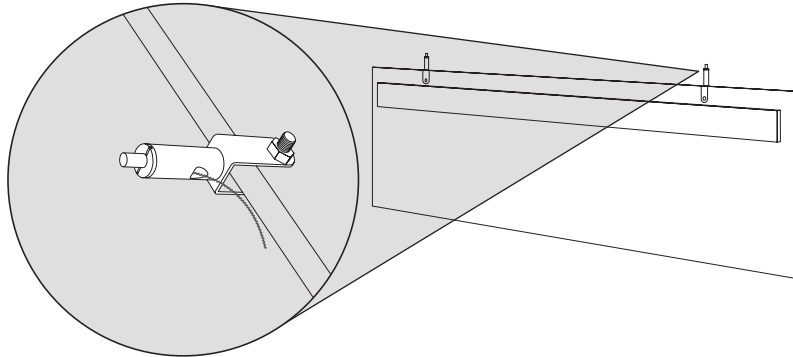

Step 4 Push the other end of the wire through the coupler by pushing in the spring adjustable button on the bottom of the coupler.

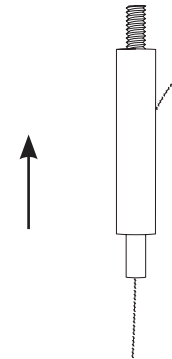

Step 5 Screw on the Unistrut Insert to the top of the Coupler Component attached to the wire.

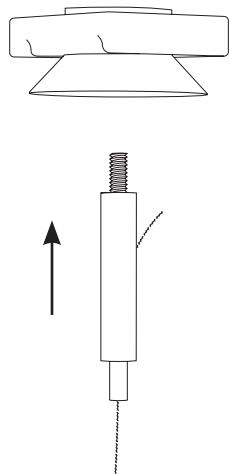

Step 6 Slide each Unistrut Insert into the Unistrut tracks. The length of the wire between the coupler and baffle should match your desired hanging length; if the length needs to be adjusted push the spring adjustable button on the bottom of the coupler and push or pull the wire to the correct length.

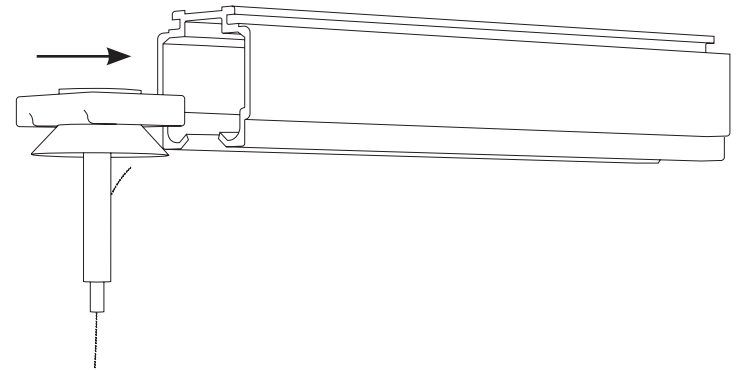

Thin t-bar grid clip assembly

Parts List

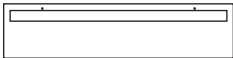

Baffle

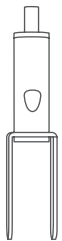

Adjustable
Clamp

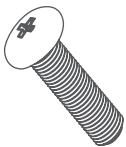

Bolt



Nut

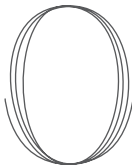

Wire

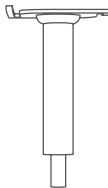

T-Bar grid
Clip

Step 1

Using a bolt and nut, attach an adjustable clamp to the baffle panel using the precut holes.

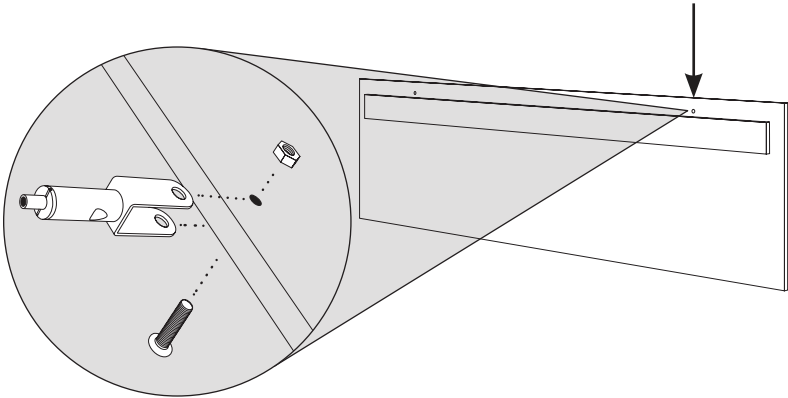

Step 2

Before cutting wire, determine the desired length and add 2-3 more inches; this will allow wiggle room for hanging. Using wire cutters, cut the wire to the desired length making sure the wire lengths match.

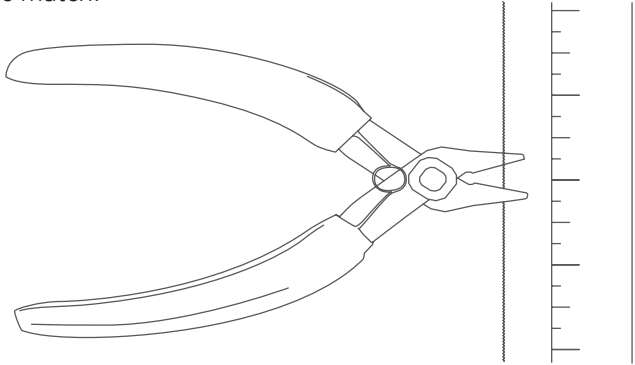

Step 3 Using the cut wire slide one end through the top of the clamp. To adjust the wire push down on the top of the clamp and pull the wire to its desired length. Do not cut any wire at this point in the process.

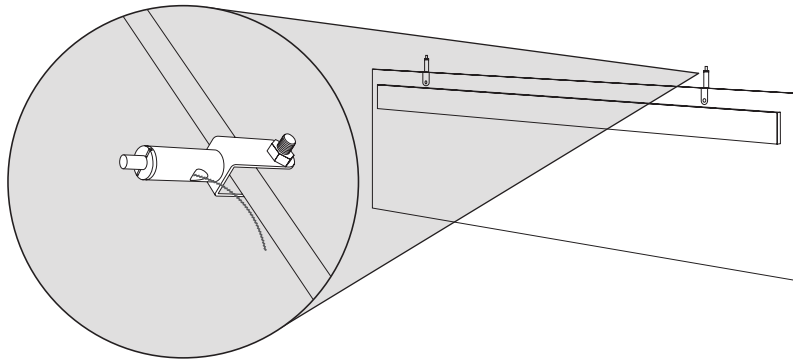

Step 4 Push the other end of the wire through the coupler by pushing in the spring adjustable button on the bottom of the coupler.

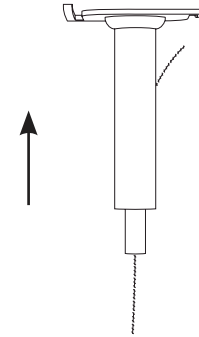

Step 5 Attach the t-bar grid clip to the grid by sliding one side onto the bracket at an angle and rotating the other side into place. The length of the wire between the coupler and baffle should match your desired hanging length; if the length needs to be adjusted push the spring adjustable button on the bottom of the coupler and push or pull the wire to the correct length.

